



COLUMBIA
COUNTY

REQUEST FOR BIDS

RESIDENTIAL DROP OFF SITE

COLUMBIA COUNTY SOLID WASTE

Issued: July 9, 2026
Due: July 30, 2026

Columbia County, Wisconsin
Greg Kaminski, Solid Waste Director
W7465 Hwy 16
Pardeeville, WI 53954
(608) 742-6651

<https://www.co.columbia.wi.us/ColumbiaCounty>

RESIDENTIAL DROP OFF SITE REQUEST FOR BID

PROJECT SCOPE

Columbia County (County) is seeking an all-inclusive proposal for a residential drop off site located at Columbia County Solid Waste, W7465 Hwy 16, Pardeeville, WI 53954. More information can be found on the County Bid Form on pages 9-15.

QUESTIONS

For interpretation or correction of any of the bid material, a request may be made to Dan Michiels, Foth Environmental, at dan.michiels@foth.com. Any questions should be received no later than Tuesday, July 21, 2026, at 2:00 p.m. (CST). Questions received after that time will not be considered. Questions and answers will be posted to [Euna Open Bids/DemandStar](#) and the [County's website](#) by 4:30 p.m. (CST) on Thursday, July 23, 2026.

PRE-BID SITE VISIT

Interested bidders can reach out to Dan Michiels at Foth Environmental if they wish to view the site prior to submitting a bid.

BID BOND

In accordance with Wisconsin Statutes Section 779.14(1m)(e), Bonds are required for the work. A 5% Bid Bond shall be delivered with the Bid on the date due.

BID SUBMISSION

Bidder must submit **three (3) copies**, including all required materials for acceptance of their bid by 1:00 p.m. (CST) on Thursday, July 30, 2026, to the Columbia County Clerk, 112 East Edgewater Street, Portage, WI 53901.

Bids will be publicly opened and read at 1:15 p.m. (CST) on Thursday, July 30, 2026, at the Columbia County Administration Building, 112 East Edgewater Street, Portage, WI 53901 in room 115.

All bids are to be packaged, sealed, and show the following information on the **outside of the package**:

- Vendor's Name and Address
- Request for Bid Title (Residential Drop Off Site)

BID RESPONSE REQUIREMENTS

In order for your bid to be considered, the following information must be provided by the due date and time.

Required documents include:

- County Bid Form (pages 9-15)
- Bid Bond
- Company and staff project experiences on projects similar in nature (include contact references).
- Timeline for schedule of completing the work.

CALENDAR OF EVENTS

Date	Event
July 9, 2026	Bid issued.
July 21, 2026	Questions related to this bid should be received no later than 2:00 p.m. (CST). Questions received after that time will not be considered
July 23, 2026	Questions and answers will be posted to Euna Open Bids/DemandStar and the County's website by 4:30 p.m. (CST).
July 30, 2026	Bids are due at 1:00 p.m. to the Columbia County Clerk, 112 East Edgewater Street, Portage, WI 53901.
July 30, 2026	Bids will be publicly opened and read at 1:15 p.m. (CST) at the Columbia County Administration Building, 112 East Edgewater Street, Room 115, Portage, WI 53901.

BID DOCUMENT

Bid price shall remain in effect for sixty (60) days from the date and time of the bid opening. All bids received after the Bid Opening date listed above may be rejected.

Any person with disability requiring special accommodations must contact the County no later than (seven) 7 days prior to the pre-bid site visit and/or bid opening.

Taxes: Pursuant to Wisconsin Statutes Section 77.54(9m), certain building materials and other eligible items may be purchased for this project by the County without the requirements to pay the regular sales or use tax. When permitted under Wisconsin Statutes Section 77.54(9m), the Bidder will exclude sales or use tax on building materials and other eligible items.

Contractor and Subcontractors shall not be barred from working on County projects and shall not appear on the Sam.gov disbarment list. A detailed listing of all subcontractors shall be provided by the Bidder prior to award of contract to assure that all workers are compliant with all qualifications required of this Request for Bid. In accordance with Contract Documents, documentation shall be submitted and provided that the Bidder and its subcontractors meet minimum qualifications of the bid.

The winning Bidder will enter into a 2-party Contract with County, in the form as outlined in the Bidding Documents, within the timeframe proposed in accordance with the other terms and conditions of the Request for Bid. The winning Bidder shall act then as prime contractor and be responsible maintaining a list of all subcontractors, suppliers, and service providers; and for payment of all claims for labor, services, materials, plans, or specifications performed, furnished, procured, used, or consumed that pertain to the project.

County hereby notifies all bidders that it will affirmatively ensure that all bidders will be afforded a full opportunity to submit bids in response to this invitation and will not be discriminated against on the grounds of race, color, sex, or national origin in consideration for an award of any contract entered into pursuant to this advertisement. Columbia County is an Equal Opportunity Employer.

County reserves the right to reject any or all bids and is not bound to accept any bid if that bid is contrary to the best interest of Columbia County. County will award the bid to the lowest responsible bidder.

General Specifications and Proposal Forms for the above-listed project may be obtained at Onvia DemandStar. Bidders must register to access free procurement documents and related information. Bidders may also obtain bid notices and documents through the Columbia County website. Bidders who do not have access to the Internet may contact Onvia or the Columbia County Accounting Department for assistance.

- **Euna Open Bids (DemandStar)**

- National procurement information distribution system.
- **Registration is FREE** in connection with the Wisconsin Association of Public Purchasers (WAPP): <https://www.demandstar.com/app/wapp/registration>
- Additional levels of subscription service covering local, state, regional, or national territories are available at various fee rates.
- Registration assistance is available: Toll free: 1-866-273-1863; supplierservices@demandstar.com

It is the responsibility of the Bidder to regularly monitor this Website. Properly registered Bidders can expect to receive automatic notification of solicitations for quotes, proposals, and bids by participating public purchasing entities. A bidder's failure to retrieve available, required procurement information and include the appropriate documentation and information in solicitation responses may result in disqualification.

Published by authority of the Columbia County Executive Committee.

BID RECIPIENT (OWNER)

- 1.01** Bid is submitted to:
Columbia County
County Clerk's Office
112 East Edgewater Street
Portage, WI 53901
- 1.02** The undersigned BIDDER proposes and agrees, if this bid is accepted, to enter into a purchase order with OWNER, to perform all Work as specified or indicated in the Bidding Documents for the prices and within the times indicated in this Bid and in accordance with the other terms and conditions of the Bidding Documents.
- 1.03** Columbia County Solid Waste staff will function as OWNER representative for this project.

BIDDER'S REPRESENTATIONS

- 2.01** In submitting this Bid, BIDDER represents; BIDDER has examined and carefully studied the Bidding Documents, other related data identified in Bidding Documents, and the following addenda; receipt of all which is hereby acknowledged;

- 2.02** BIDDER has visited the site and become familiar with and is satisfied as to the general, local and site conditions that may affect cost, progress, and performance of the Work.
- 2.03** BIDDER acknowledges that the bid is for a residential drop off site located at Columbia County Solid Waste, W7465 Hwy 16, Pardeeville, WI 53954.
- 2.04** **BIDDER ACKNOWLEDGES BID IS A UNIT PRICE CONTRACT** for completion of all work and minor alternatives for consideration of each owner identified bid item(s); within the depicted areas as specified in the bid documents.

- 2.05 BIDDER SHALL BE RESPONSIBLE TO VERIFY THE PROJECT QUANTITY.** Quantities as presented or represented within the Bid Documents are included to provide the actual quantity of equipment to be provided. BIDDER shall verify and assure proper account of project scope prior to formation and submittal of unit pricing for the project. Change orders shall NOT be allowed for BIDDER'S negligence or variance in based on "assumed" versus "actual" quantities required for the project.
- 2.06** BIDDER shall perform all work in a safe manner in full legal accordance with OSHA, Federal, State, County, Town, WDNR, and local rules and regulations.
- 2.07** BIDDER accepts all of the terms and conditions of the Bid. This Bid will remain subject to acceptance for 60 days after the Bid Opening, or for such longer period of time that Bidder may agree to in writing upon request of OWNER.
- 2.08** BIDDER is familiar with and is satisfied as to all Laws and Regulations that may affect cost, progress, and performance of the Work including, but not limited to;
- 2.08.1** Title VIII of the Federal Civil Rights Act of 1968 (as amended), and Wisconsin Statutes Section 106.50, and any subsequent relevant laws or amendments.
- 2.09** After BID has been submitted, BIDDER shall not assert that there was a misunderstanding concerning the quantities of equipment to be provided, or nature of project to be completed.
- 2.10** BIDDER is responsible for inspecting the site and for being thoroughly familiar with the Bidding Documents. Failure or omission of BIDDER to conduct due diligence shall in no way relieve BIDDER from any obligations in respect to BID. Based on the information and observations referred to, BIDDER does not consider that further examinations, investigations, explorations, tests, studies, or data are necessary for the determination of this Bid for performance of the Work at the price(s) bid and within the timeframes required, and in accordance with the other terms and conditions of this Bid.
- 2.11** BIDDER is aware of the general nature of work to be performed by OWNER, the public, and others at the Site that relates to the Work as indicated in this Bid. BIDDER also represents that Work performed in accordance with this bid shall not interfere with OWNER or public's performance of work.
- 2.12** BIDDER has provided OWNER written notice of all conflicts, errors, or discrepancies that BIDDER has discovered. For any conflicts, errors, or discrepancies identified, the resolution provided by OWNER is acceptable to BIDDER.
- 2.13** BIDDER has not engaged in corrupt, fraudulent, collusive, or coercive practices in competing for this contract. Bid is genuine and not made in the interest or on behalf of any undisclosed entity and is not submitted in conformity with any collusive agreement. BIDDER has not induced or solicited any other BIDDER to submit a false or sham bid. BIDDER has not solicited or induced any entity to refrain from bidding.

BASIS OF THE BID

- 3.01** The executed purchase order will bind OWNER to make payment to the successful BIDDER as unit price payments based upon completion of the work. Payment shall be made by progress payment method based on actual quantity of work performed; determined as completion of the unit price item(s) contract amount and provided the work is completed in timely, professional, safe, efficient, consistent manner, acceptable to OWNER.

- 3.02** BID shall be inclusive of all labor, equipment, materials, overhead, supervision, fuel, taxes, insurance, benefits, profit and all other costs deemed necessary to fulfill requirements of the Work.
- 3.03** Work under this Bid shall be Finally Complete and ready for Owner's acceptance on the due date.
- 3.04** BIDDER's obligations will be coordinated with OWNER and shall be performed independently and without assistance from the OWNER.
- 3.05** OWNER reserves the right to nullify the purchase order between OWNER and BIDDER in the event BIDDER is unable to fulfill its obligation, at OWNER's sole determination. Purchase order termination, if enacted, shall be effective immediately upon BIDDER'S receipt of written notice from OWNER.
- 3.06** BIDDER shall warrant all work performed by Bidder in relation to this Contract for a period of one (1) year from Final Completion certification of project; unless otherwise specified within the Bid.
- 3.07** BID is a Unit Price for a residential drop off site located at Columbia County Solid Waste, W7465 Hwy 16, Pardeeville, WI 53954. OWNER has the right to award single or multiple unit price item(s) at OWNER'S discretion.

PROJECT IDENTIFICATION

Work of the Contract shall be conducted in accordance with the following conditions:

- 4.01** The purpose of this project is for a residential drop off site located at Columbia County Solid Waste, W7465 Hwy 16, Pardeeville, WI 53954. For the price quoted in relation to this project, BIDDER shall provide all labor, equipment, materials, taxes, overhead, fuel, subcontractors, and all other direct and indirect costs necessary in accordance with the Contract Documents.
- 4.02** BIDDER shall be solely, wholly, and completely responsible for the safety of all employee(s) working in connection with this project. Work shall conform to all safety related Statutes, rules, ordinances, and guidance whether at the federal, state, county, or local level.
- 4.03** BIDDER shall coordinate and procure all necessary permits, prior to initiating work on-site.
- 4.04** The work is generally described as a residential drop off site located at Columbia County Solid Waste, W7465 Hwy 16, Pardeeville, WI 53954. This is a Unit Price Bid. BIDDER shall be responsible for conducting their own material take-off, field measurements, fit determinations, and procuring the correct amount of materials needed to complete the work as specified. OWNER merely provides the following for informational purposes to allow a prospective bidder to easily approximate the amount of work needed for this project to determine their interest level in the project. BIDDER is responsible for determining proper measurements.

PROCEDURAL SPECIFICATIONS (BIDDER'S RESPONSIBILITIES)

- 5.01** Proceed expeditiously so as to complete all work in a reasonable timeframe. All areas opened during the daytime, shall be secured and protected during hours when the BIDDER is not working.
- 5.02** Maintain work areas in a safe, efficient, professional manner. Protect and store all work areas, equipment, materials, and tools in a secure, safe, protected area.

5.03 COVID-19 Protocols

- 5.03.1** Any employee or worker experiencing Covid-like symptoms shall not be allowed to work at the Facility or on the project until such time as they are required to no longer quarantine and should follow all CDC guidelines.
- 5.03.2** Owner will be held harmless for any delay of installation/construction due to the event of a COVID-19 outbreak within the facility.

USE OF PREMISES (BIDDER'S RESPONSIBILITIES)

This is an active Facility. Staff and permitted public personnel frequent the work areas. BIDDER shall operate at all times with consideration for Facility operations and shall confine operations to the site of the proposed work.

- 6.01** Responsibility for the protection and safekeeping of manpower, equipment, and materials on or near the site will be entirely that of the BIDDER and no claim shall be made against the OWNER by reason of any act of an employer or trespasser. OWNER will hold BIDDER to the highest standards of conduct.
 - 6.01.1** Appropriate conduct is required.
 - 6.01.2** A criminal background check shall be required of all BIDDER personnel that access the Facility. BIDDER shall provide a minimum of three (3) working days advance notice to Facility prior to conducting work on site and shall continue working expeditiously and continuously for the duration of that specific activity. Daily work hours shall be completed Monday thru Friday, beginning at 7:00 a.m.
 - 6.01.3** BIDDER shall not leave any work area, tools, chemicals, supplies, etc. unattended.
- 6.02** Any Facility damage caused by BIDDER shall be repaired to pre-existing condition at BIDDER's expense.
- 6.03** Further, should any occasion arise necessitating access by the OWNER to the site, BIDDER shall accommodate the request expeditiously.
- 6.04** No materials or equipment shall be placed on the property of OWNER until the OWNER has agreed to the location contemplated to be used. The intent of this project is the rapid construction and installation of all work; therefore, excessive storage of materials at the site shall not occur.
 - 6.04.1** Upon completion of the project, all excess material shall be removed from the site and properly disposed of at the cost of the BIDDER.
 - 6.04.2** BIDDER shall police the area frequently to assure there is no migration of debris, glass, nails, or other sharp objects which could damage staff, passersby, vehicles, or equipment.
- 6.05** BIDDER shall be solely responsible for obtaining any additional work area, storage sites, additional access to the site, or temporary right-of-way or easement which may be required for proper completion of the work, at BIDDER'S exclusive cost.
- 6.06** BIDDER shall be solely responsible to maintain the structural and security integrity of any/all adjacent utilities, structures, or public spaces and take whatever means are necessary to protect same.
 - 6.06.1** Fixtures or areas removed or destroyed shall be repaired and replaced to satisfaction of the OWNER.

SCHEDULING (BIDDER'S RESPONSIBILITIES)

Become familiar with all items of the project requiring coordination and plan the work to ensure safe, orderly progress and completion from the beginning of activity through the project close-out period, within the Contract time.

- 7.01** Schedule the work to minimize inconvenience and impact to the OWNER and adjacent property owners.
- 7.02** Once project has started, BIDDER shall continue unimpeded, expeditiously, continuously and in a consistent manner in order to complete the project in the utmost timeframe and without detrimental collateral damage to either the existing buildings or their surroundings.
- 7.03** Coordinate closely with Facility staff, providing at least three (3) working days' notice prior to the time when field work will be required.
- 7.04** Minimize obstructions and impact to Facility activity.
- 7.05** Coordinate activity with the OWNER to minimize disruption at the site.
- 7.06** Provide testing and inspection services where required by Contract Documents.
- 7.07** Schedule and coordinate the work of all trades (including; but not limited to, other contractors, subcontractors, utilities, disposal locations, suppliers, etc.) under this Contract.
- 7.08** No project work shall be initiated until notified by COUNTY via the purchase order.

HOUSEKEEPING (BIDDER'S RESPONSIBILITIES)

Clean and protect site work in progress and adjoining work on a continual basis in order to keep project neat, orderly, and in a safe condition at all times.

- 8.01** Provide containers for collection of rubbish and dispose of it at frequent intervals during work progress. Do not allow rubbish to accumulate.
- 8.02** Take all necessary reasonable measures to reduce air and water pollution from any material or equipment used during construction.
- 8.03** Do not dispose of volatile wastes or oils in storm or sanitary drains, nor allow such materials to reach natural waters. Do not allow volatile wastes to be washed into surface water bodies. Keep volatile waste in covered containers.
- 8.04** No burning of debris will be permitted.
- 8.05** Take all necessary precautions to prevent fire during performance of the Contract; provide and maintain adequate fire protection at all times. Provide adequate ventilation during use of volatile or noxious substances.

INDUSTRY STANDARDS (BIDDER'S RESPONSIBILITIES)

- 9.01** Remove and replace workers responsible for non-complying work and/or workmanship.
- 9.02** Remove and replace work that does not comply with workmanship standards as specified and as recognized in the industry for applications indicated.
- 9.03** Remove and replace other work damaged or deteriorated by faulty workmanship.
- 9.04** Conduct work during conditions of temperature, humidity, exposure, forecasted weather, and status of project completion that will ensure the best possible results for each unit of work.
- 9.05** Provide adequate supervision, labor, equipment, materials, and expertise in order to complete work timely, safe, effective, and efficiently for the duration of the project.
- 9.06** Normal work hours shall be Monday thru Friday, beginning at 7:00 a.m., not including holidays. Any work performed outside of these normal hours, except work identified as an emergency, requires OWNER'S prior approval.
- 9.07** Persons performing work at the site shall be skilled and knowledgeable in methods and craftsmanship needed to produce the required quality level for work completed in a safe, efficient, effective manner.
- 9.08** Comply with Federal Project and Employment Standards and Requirements; including but not limited to, National Environmental Policy Act of 1969, Affirmative Action Requirements (EO 11246), Equal Opportunity Clause (41 CFR 60-4), Disclosure of Lobbying Activities (31 U.S.C. 1352), and Conflict of Interest (18 U.S.C. § 208).

STATUTORY GUIDANCE ON BONDING AND PROJECT PAYMENTS

- 10.01** OWNER is authorized to enter into the Contract to make direct payment to subcontractors or to pay the prime contractor with checks that are made payable jointly to the prime contractor and to one or more subcontractors. Wisconsin Statutes Section 779.14(1m)(d)1. for local government contracts exceeding \$16,000 but not exceeding \$74,000.
- 10.02** Performance and Payments bonds of this Contract and as required under Wisconsin Statutes Section 779.14(1m)(d) must carry a penalty in at least the amount of the Contract, and be conditioned upon: (1) the faithful performance of the Contract; and (2) the payment to "every person, including every subcontractor, supplier, or service provider, of all claims that are entitled to payment for labor, services, materials, plans, or specifications performed, furnished, or procured for the purpose of making the public improvement or performing the public work as provided in the contract. Wisconsin Statutes Section 779.14(1m)(e)2.
- 10.03** Local government contracts with a price exceeding \$74,000 but not exceeding \$148,000 may provide for direct payment if the local government allows the prime contractor to substitute a different payment assurance, such as an irrevocable letter of credit or an escrow account in lieu of bonding requirements (Wisconsin Statutes Section 779.14(1m)(d)2).
- 10.04** The requirements to provide bonding or other payment assurances "do not apply to ... contract[s] for the direct purchase of materials by the state or ... local unit of government." (Wisconsin Statutes Section 779.14(1m)(f). A prime contractor for a public works project must provide a bond only for the labor and materials in its own contract.

COUNTY BID FORM

Bidder shall complete the work in accordance with the Contract Documents for the following price(s).

PROJECT NAME: RESIDENTIAL DROP OFF SITE

CONTRACTOR NAME: _____

PRE-BID SITE VISIT

Interested bidders can reach out to Dan Michiels, Foth Environmental, at dan.michiels@foth.com, if they wish to view the site prior to submitting a bid.

BID BOND

In accordance with Wisconsin Statutes Section 779.14(1m)(e), Bonds are required for the work. A 5% Bid Bond shall be delivered with the Bid on the date due.

PROJECT SPECIFICATIONS

Section 01 22 01 Measurement and Payment

Part 1 - General

1.1 Summary

A. Section includes:

	Bid Item I.D.
1. General Work Items	NA
2. Mobilization and Demobilization	1
3. Structural Fill with Onsite Material	2
4. Base Aggregate Dense	3
5. Concrete Retaining Wall and Pads	4
6. Catch Basin and Pipe	5
7. Restoration	6
8. Optional Bid Item – Installation of Communication and Electrical Conduits for Light Pole	A
9. Alternate Bid Item – Structural Fill with Imported Material	2A
10. Alternate Bid Item – Base Aggregate Dense – Owner Supplied	3A

B. Unit Prices include:

1. Defined work for each Unit Price Item which will provide a functionally complete Project when combined with all Unit Price Items. If there are specific work items which the Contractor believes are not identified in any Unit Price Item, but is required to provide a functionally complete Project, then the identified specific work items shall be included in the appropriate Unit Price Item.
2. The method of measurement for payment.
3. The price per unit for payment.

- C. Lump Sum Prices include:
 - 1. All work items which will result in a functionally complete project in accordance with the specifications and figures.

1.2 General Work Items

- A. Include with the appropriate Bid Item the following work items which are common to the Proposal Items for this Section.
- B. If there is a specific Bid Item for any of the following items, then the work item shall be included with that specific unit price item.
 - 1. All costs associated with the mobilization and demobilization of equipment and personnel.
 - 2. All costs associated with providing temporary facilities required to complete the work.
 - 3. Maintenance, protection, replacement and/or repair of damaged facilities outside the area identified for payment in a separate Unit Price Item.
 - 4. All necessary building and regulatory permits.
 - 5. Dust control.
 - 6. Traffic control and coordination with ongoing transfer station and recycling facility operations.
 - 7. Erosion control construction.
 - 8. Right-of-way requirements.
 - 9. Regulatory requirements.
 - 10. Construction staking and other survey work not provided by Owner's representative.
 - 11. Location of existing utilities and piping.
 - 12. Protection of existing underground piping and utilities.
 - 13. Quality assurance and quality control testing and inspections not provided by the Owner's representative.
 - 14. All safety related costs.
 - 15. Shop drawings and other submittals.

1.3 Mobilization and Demobilization (Bid Item 1)

- A. The unit price for Bid Item 1 work includes:
 - 1. General Work Items of Article 1.2.

2. All costs associated with the mobilization and demobilization of equipment and personnel.
- B. Measurement for payment will not be made.
- C. The unit of measurement for payment is lump sum.

1.4 Structural Fill with Onsite Material (Bid Item 2)

- A. The unit price for Bid Item 2 work includes:
1. General Work Items of Article 1.2.
 2. Excavation, hauling, placement, and compaction of structural fill material obtained from onsite stockpile.
 3. Grading areas to be paved to design sub-base grades.
 4. Proof rolling and finish grading.
- B. Measurement for payment will not be made.
- C. The unit of measurement for payment is lump sum.

1.5 Base Aggregate Dense (Bid Item 3)

- A. The unit price for Bid Item 3 work includes:
1. General Work Items of Article 1.2.
 2. Furnish, hauling, placement, and compaction of virgin base aggregate dense.
 3. Grading areas to be paved to design grades.
 4. Proof rolling and finish grading.
- B. Measurement for payment will be based on the actual tonnage of base aggregate dense placed. Method of payment will be based on scale tickets from supplier.
- C. The unit of measurement for payment is tons. An estimated material amount of 805 tons will be used for bid comparison purposes and actual tonnage will vary.

1.6 Concrete Retaining Wall and Pads (Bid Item 4)

- A. The unit price for Bid Item 4 work includes:
1. General Work Items of Article 1.2.
 2. Provide shop drawings and mix designs for pad construction.
 3. Furnishing and installing reinforced concrete pads and retaining walls in accordance with plans and specifications.

4. All required concrete testing.
 5. Paint curbs.
- B. Measurement for payment will not be made.
- C. The unit of measurement for payment is lump sum.

1.7 Catch Basin and Pipe (Bid Item 5)

- A. The unit price for Bid Item 5 work includes:
1. General Work Items of Article 1.2.
 2. Locating and protecting existing utilities and piping.
 3. Excavation of trench for catch basin and piping.
 4. Furnish and install bedding material.
 5. Furnish and install concrete catch basin.
 6. Furnish and install PVC pipe and outlet protection.
- B. Measurement for payment will not be made.
- C. The unit of measurement for payment is lump sum.

1.8 Restoration (Bid Item 6)

- A. The unit price for Bid Item 6 work includes:
1. General Work Items of Article 1.2.
 2. Installation of erosion control devices including silt fence or straw wattles.
 3. Seed, fertilize, and erosion mat areas as shown on the plans.
 4. General site cleanup.
 5. Removal of all temporary facilities and utilities.
 6. Removal of all excess materials (unless otherwise directed by Owner).
 7. Restoration of all areas disturbed by construction.
 8. Removal of stormwater erosion control devices including silt fence or straw wattles.
- B. Measurement for payment will not be made.
- C. The unit of measurement for payment is lump sum.

Optional Bid Item

1.9 Installation of Communication and Electrical Conduits for Light Pole (Optional Bid Item A)

- A. The unit price for Optional Bid Item A work includes:
 - 1. General Work Items of Article 1.2.
 - 2. Locating and protecting existing utilities and piping.
 - 3. Construction staking and layout.
 - 4. Excavation and removal of drill spoils from hole.
 - 5. Furnish and install conduits with pull strings for future electric and communications lines.
 - 6. Connection of conduits to existing points as shown on Drawings.
 - 7. Sawcutting of road and asphalt patching to be done by Others.
- B. Measurement for payment will not be made.
- C. The unit of measurement for payment is lump sum.

Alternate Bid Items

1.10 Structural Fill with Imported Material (Alternate Bid Item 2A)

- A. The unit price for Bid Item 2 work includes:
 - 1. General Work Items of Article 1.2.
 - 2. Furnish, hauling, placement, and compaction of structural fill material.
 - 3. Grade areas to design grades.
 - 4. Proof rolling and finish grading.
- B. Measurement for payment will not be made.
- C. The unit of measurement for payment is lump sum.

1.11 Base Aggregate Dense – Owner Supplied (Alternate Bid Item 3A)

- A. The unit price for Bid Item 2 work includes:
 - 1. General Work Items of Article 1.2.
 - 2. Loading, hauling, placement, and compaction of Owner supplied salvaged base aggregate dense.
 - 3. Grading areas to be paved to design grades.

4. Proof rolling and finish grading.
- B. Measurement for payment will be based on the actual tonnage of salvaged base aggregate dense placed. Method of payment will be based on scale tickets for loaded vehicles from Owner scale.
- C. The unit of measurement for payment is tons. An estimated material amount of 805 tons will be used for bid comparison purposes and actual tonnage will vary.

Section 00 41 43

UNIT PRICE BID SCHEDULE

Item No.	Description	Unit	Est. Quantity	Bid Unit Price	Extension
1	Mobilization and Demobilization	Lump Sum	1	\$	\$
2	Structural Fill with Onsite Material	Lump Sum	1	\$	\$
3	Base Aggregate Dense	Ton	805	\$	\$
4	Concrete Retaining Wall and Pads	Lump Sum	1	\$	\$
5	Catch Basin and Pipe	Lump Sum	1	\$	\$
6	Restoration	Lump Sum	1	\$	\$
Total Bid Price (Items 1-6) =					\$

Note: The listed number of units for bid items are for comparison purposes only and are not guaranteed. Payment will be based on the actual number of units determined by methods described in Section 01 22 01.

Optional Bid Item

The following optional bid item may be selected by the Owner.

A	Installation of Communication and Electrical Conduits for Light Pole	Lump Sum	1	\$	\$
---	--	----------	---	----	----

Alternate Bid Items

The following optional bid items may be selected by the Owner.

2A	Structural Fill with Imported Material	Lump Sum	1	\$	\$
3A	Base Aggregate Dense - Owner Supplied	Lump Sum	1	\$	\$

Any add-on options need to be listed separately and clearly specified with the cost.

SUBMITTED BY

PROJECT NAME: RESIDENTIAL DROP OFF SITE

Contractor Name: _____

Address: _____

Email: _____

Phone: _____

Contact Name: _____

Title: _____

Signature: _____ Date: _____

Date of qualification to do business in Wisconsin: _____

CONTRACT DOCUMENT

PROJECT NAME: RESIDENTIAL DROP OFF SITE

This CONTRACT is dated as of the _____ day of _____, 20_____, by and between Columbia County, Wisconsin, (Owner) and _____, (Contractor). Owner and Contractor, in consideration of the mutual covenants hereinafter set forth, agree as follows:

Article 1. WORK. Contractor shall complete all work as specified or indicated in the Contract Documents. The work is generally described as a residential drop off site located at Columbia County Solid Waste, W7465 Hwy 16, Pardeeville, WI 53954. All equipment, materials, labor, overhead, taxes, and all other costs are included in order to complete the work in accordance with the Contract Documents.

Article 2. OWNER DESIGNATIONS. The following representative has been identified in relation to this project.

Owner:	Columbia County 112 E Edgewater Street Portage, WI 53901
--------	--

Owner Representative:	Greg Kaminski
-----------------------	---------------

Article 3. CONTRACT TIMES. The Work will be conducted during normal business hours.

Article 4. CONTRACT PRICE. Owner shall pay Contractor for completion of the Work in accordance with the Contract Documents an amount in current funds not to exceed \$_____.

Article 5. PAYMENT PROCEDURES. Progress draws and payments will be allowed at the end of each month for proportional work completed. Progress payments shall be made in an amount equal to 100 percent of proportional work completed and 100 percent of proportional materials and equipment incorporated in the Work, less in each case, the aggregate of payments previously made. Owner retains the right to reduce Contractor's pay application amount if Owner determines that Contractor has not performed appropriately on the project or in the event that Owner feels Contractor is over billing the project. Contractor shall be notified in writing within fifteen (15) business days; in event Owner determines it necessary to reduce a payment amount.

Contractor shall submit an application for payment to Owner prior to the 30th day of each month. Payments are made by the 25th of each subsequent month.

Article 6. CONTRACTOR'S REPRESENTATIONS. In order to induce Owner to enter into this Contract, Contractor makes the following representations:

- 6.1 Contractor has examined and carefully studied the Contract Documents and other related data identified in the Bid Documents.
- 6.2 Contractor has visited the site, become familiar with, and is satisfied as to the general, local and site conditions that may affect cost, progress, performance or furnishing of the Work.
- 6.3 Contractor is familiar with and is satisfied as to all Federal, State, and local Laws and Regulations that may affect cost, progress, performance and furnishing of the Work.

- 6.4 Contractor is aware of the general nature of work to be performed by Owner and others at the site that relates to the Work as indicated in the Contract Documents.
- 6.5 Contractor has correlated the information known to Contractor, information and observations obtained from visits to the site and reports and drawings identified in the Contract Documents to Owner.
- 6.6 Contractor will comply with Federal Project and Employment Standards and Requirements; including but not limited to, National Environmental Policy Act of 1969, Affirmative Action Requirements (EO 11246), Equal Opportunity Clause (41 CFR 60-4), Disclosure of Lobbying Activities (31 U.S.C. 1352), and Conflict of Interest (18 U.S.C. § 208).
- 6.7 Contractor has given Owner written notice of all conflicts, errors, ambiguities or discrepancies that Contractor has discovered in the Contract Documents. Contractor acknowledges that the Contract Documents are sufficient to indicate and convey an understanding of all terms and conditions for performance and furnishing of the Work.
- 6.8 Contractor estimates that the work will be completed on or around _____. If it is necessary for the work to extend beyond _____, Contractor will make every effort to finish the Work within a reasonable timeframe.

Article 7. CONTRACT DOCUMENTS. The Contract Documents, which comprise the entire agreement between Owner and Contractor concerning the Work, consist of the following:

- 7.1 This Agreement; three (3) pages inclusive.
- 7.2 Columbia County Terms and Conditions, five (5) pages inclusive.
- 7.3 County's Request for Bid.
- 7.4 Contractor's Bid documents.
- 7.5 Any modifications, including Change Orders, duly delivered after execution of this Contract.

There are no Contract Documents other than those listed above in this Article 7. The Contract Documents may only be amended, modified, or supplemented if agreed to, in writing, by both Owner and Contractor.

Article 8. MISCELLANEOUS.

- 8.1 No assignment by a party hereto of any rights under or interests in the Contract Documents will be binding on another party hereto without the written consent of the party sought to be bound; and, specifically but without limitation, moneys that may become due and moneys that are due may not be assigned without such consent (except to the extent that the effect of the restriction may be limited by law), and unless specifically stated to the contrary in any written consent to an assignment, no assignment will release or discharge the assignor from any duty or responsibility under the Contract Documents.
- 8.2 Owner and Contractor each binds itself, its partners, successors, assigns, and legal representatives to the other party hereto, in respect to all covenants, agreements and obligations contained in the Contract Documents.

8.3 Any provision or part of the Contract Documents held to be void or unenforceable under any Law or Regulation shall be deemed stricken, and all remaining provisions shall continue to be valid and binding upon Owner and Contractor, who agree that the Contract Documents shall be reformed to replace such stricken provision or part thereof with a valid and enforceable provision that comes as close as possible to expressing the intention of the stricken provision.

8.4 Owner and Contractor hereby agree that this Contract shall be governed by the laws of the State of Wisconsin and the lawful court for proper resolution of any or all legal actions shall be the Columbia County, Wisconsin, Circuit Court.

IN WITNESS WHEREOF, Owner and Contractor have signed this Contract with a fully signed copy provided to each.

This Contract will be effective on receipt of the executed document by Contractor from Owner.

Owner:

Columbia County
112 E Edgewater Street
Portage, WI 53901

Contractor Name & Address:

By: _____

Greg Kaminski
Solid Waste Director

By: _____

(Signature)

(Printed Name)

Address for giving notices:

Columbia County
112 E Edgewater Street
Portage, WI 53901
(608) 742-9801

Address for giving notices:
(Contractor Name/Address)



RESIDENTIAL DROP-OFF

COLUMBIA COUNTY RECYCLING & SOLID WASTE
PARDEEVILLE, WISCONSIN

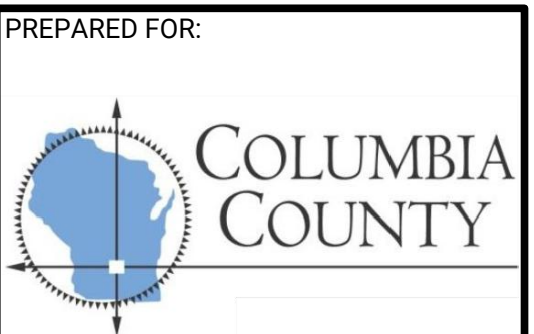

OWNER CONTACT INFORMATION
GREG KAMINSKI, DIRECTOR COLUMBIA COUNTY SOLID WASTE W7465 HWY 16 PARDEEVILLE, WI 53954 (608) 742-6651 greg.kaminski@columbiacountywi.gov
ENGINEER CONTACT INFORMATION
DAN MICHIELS, P.E. FOTH INFRASTRUCTURE & ENVIRONMENT, LLC 2121 INNOVATION COURT, SUITE 100 DE PERE, WI 54115 (920) 496-6865 dan.michiels@foth.com
PROJECT ADDRESS
COLUMBIA COUNTY RECYCLING AND SOLID WASTE W7465 HWY 16 PARDEEVILLE, WI 53954

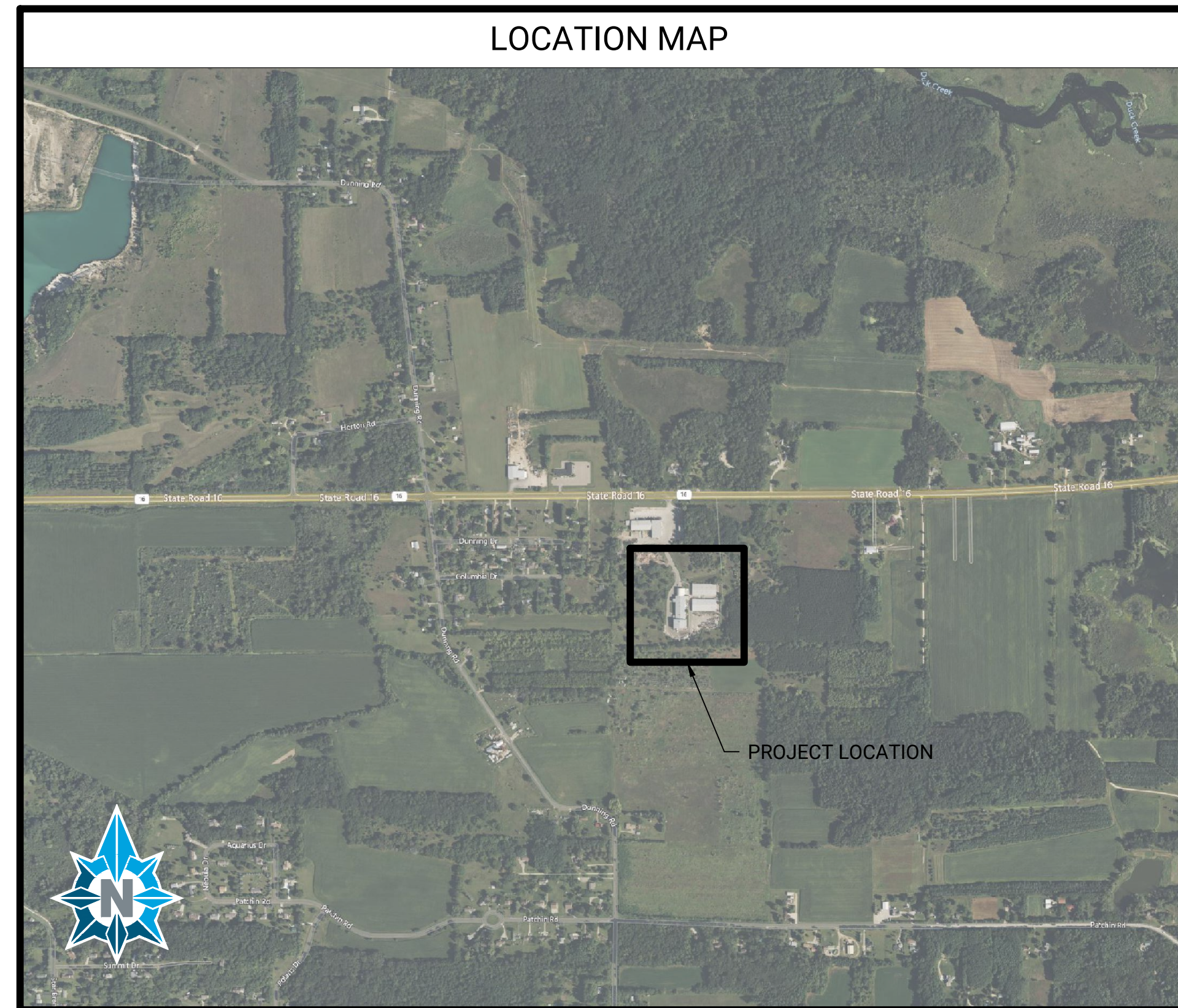

INDEX OF SHEETS

SHEET NO.	SHEET TITLE
G1.0	COVER SHEET
G2.0	GENERAL NOTES
G2.1	GENERAL NOTES
C1.0	EXISTING CONDITIONS
C2.0	PROPOSED SITE PLAN
C2.1	PROPOSED LIGHT POLE PLAN
C3.0	PROPOSED GRADING PLAN
C5.0	DETAILS
C5.1	DETAILS
C5.2	DETAILS
C5.3	DETAILS

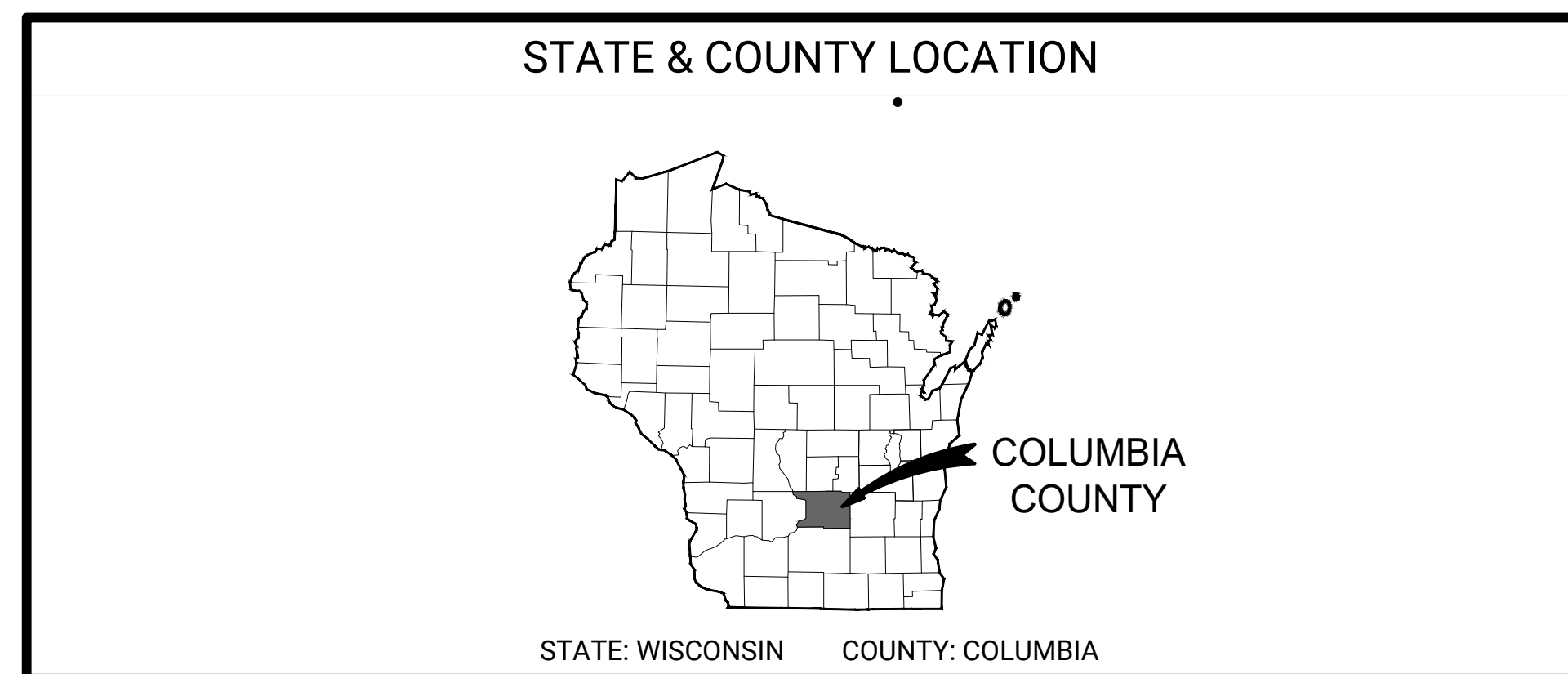

REVISION DESCRIPTION

NO	DATE	BY	REVISION DESCRIPTION
1.	6/26/2026	ATP	ISSUED FOR OWNER REVIEW
2.	7/1/2026	ATP	ISSUED FOR BIDDING

RESIDENTIAL DROP-OFF
COLUMBIA COUNTY RECYCLING & SOLID WASTE
PARDEEVILLE, WISCONSIN

COVER SHEET

FOTH PROJ. #: 26C062.00

VERTICAL DATUM:
NAVD88

HORIZONTAL DATUM:
WISCONSIN COORDINATE REFERENCE SYSTEM
(WisCRS), COLUMBIA COUNTY, NAD83

ANY SURVEY MONUMENTS THAT ARE DAMAGED
MUST BE REPLACED IN ACCORDANCE WITH
WISDOT S.D.D. 16 A 01



STAMPS

C - CIVIL SHEETS G1.0 TO C5.3

ISSUED FOR BIDDING

DESIGNED: ATP	DRAWN: ATP	CHECKED: DJM4
PROJECT NO: 26C062.00		
PRINT DATE: 7/1/2026		
SHEET NO.		
G1.0		

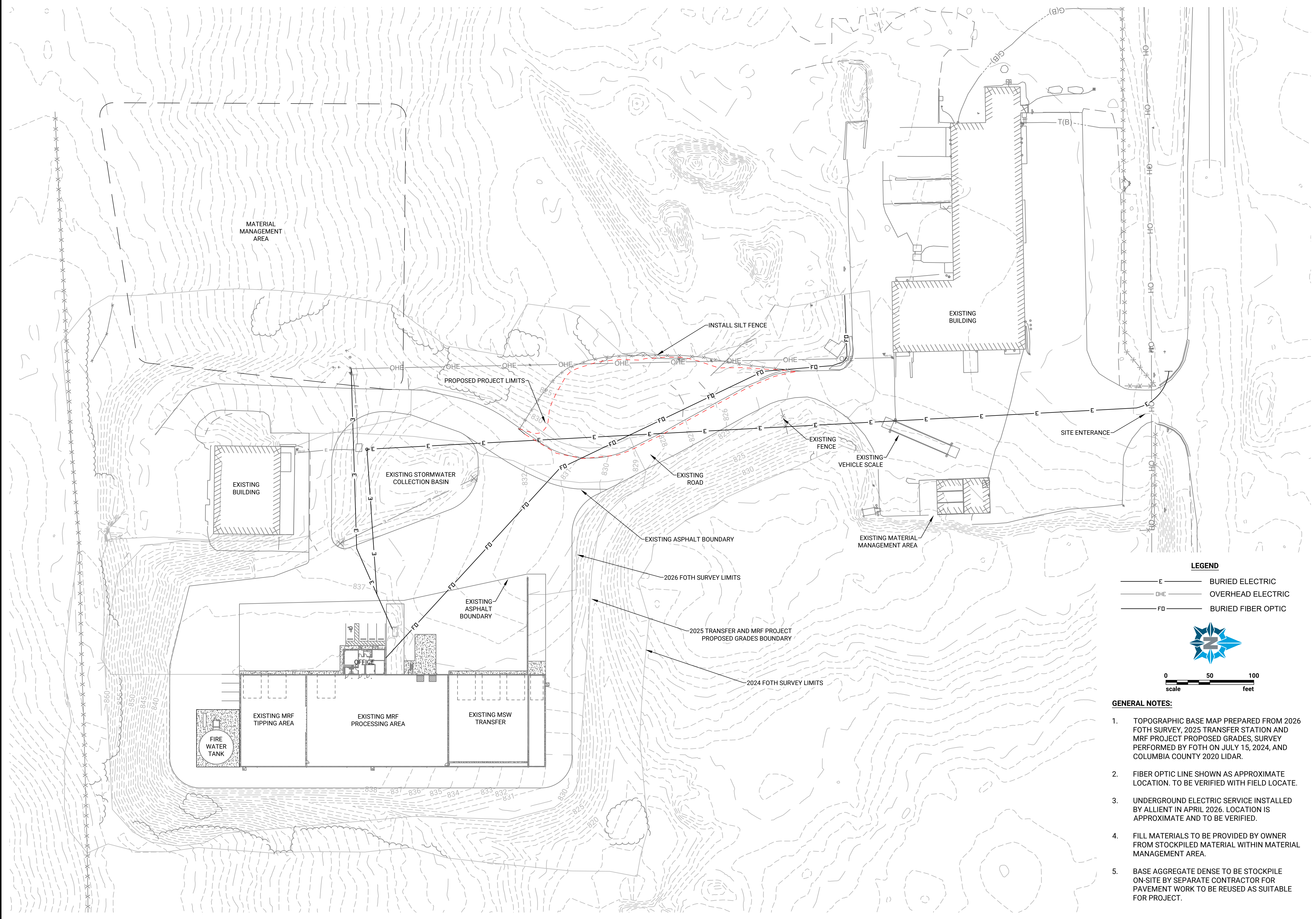

NO	DATE	BY	REVISION DESCRIPTION
1.	6/26/2026	ATP	ISSUED FOR OWNER REVIEW
2.	7/1/2026	ATP	ISSUED FOR BIDDING

RESIDENTIAL DROP-OFF
 COLUMBIA COUNTY RECYCLING & SOLID WASTE
 PARDEEVILLE, WISCONSIN

EXISTING CONDITIONS

LEGEND

- E — BURIED ELECTRIC
- OHE — OVERHEAD ELECTRIC
- FO — BURIED FIBER OPTIC

0 50 100
 scale feet

- GENERAL NOTES:**
- TOPOGRAPHIC BASE MAP PREPARED FROM 2026 FOTH SURVEY, 2025 TRANSFER STATION AND MRF PROJECT PROPOSED GRADES, SURVEY PERFORMED BY FOTH ON JULY 15, 2024, AND COLUMBIA COUNTY 2020 LIDAR.
 - FIBER OPTIC LINE SHOWN AS APPROXIMATE LOCATION. TO BE VERIFIED WITH FIELD LOCATE.
 - UNDERGROUND ELECTRIC SERVICE INSTALLED BY ALLIENT IN APRIL 2026. LOCATION IS APPROXIMATE AND TO BE VERIFIED.
 - FILL MATERIALS TO BE PROVIDED BY OWNER FROM STOCKPILED MATERIAL WITHIN MATERIAL MANAGEMENT AREA.
 - BASE AGGREGATE DENSE TO BE STOCKPILE ON-SITE BY SEPARATE CONTRACTOR FOR PAVEMENT WORK TO BE REUSED AS SUITABLE FOR PROJECT.

ISSUED FOR BIDDING

DESIGNED: ATP	DRAWN: ATP	CHECKED: DJM4
PROJECT NO: 26C062.00		
PRINT DATE: 7/1/2026		
SHEET NO.		
C1.0		

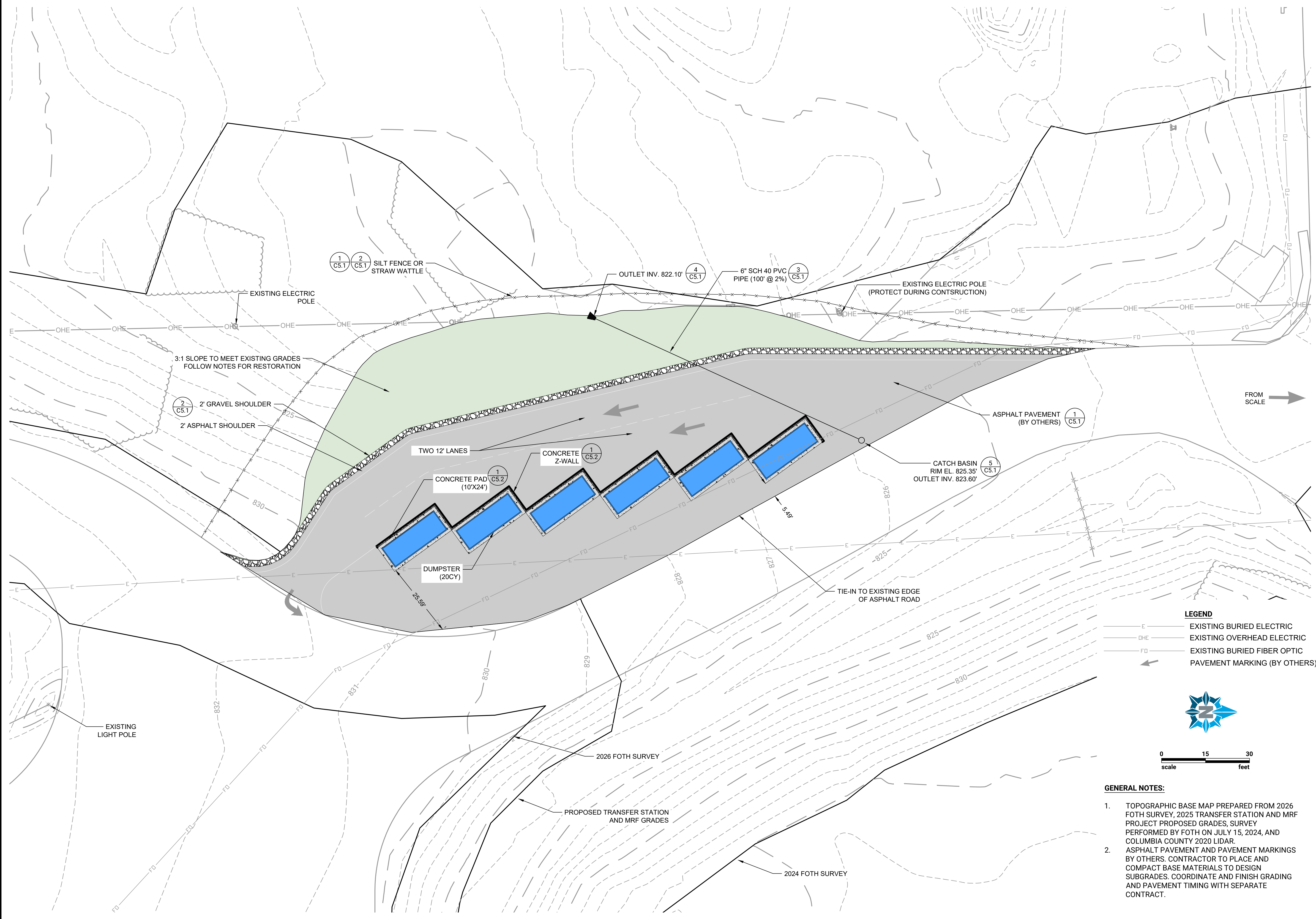

NO	DATE	BY	REVISION DESCRIPTION
1.	6/26/2026	ATP	ISSUED FOR OWNER REVIEW
2.	7/1/2026	ATP	ISSUED FOR BIDDING

RESIDENTIAL DROP-OFF
 COLUMBIA COUNTY RECYCLING & SOLID WASTE
 PARDEEVILLE, WISCONSIN
PROPOSED SITE PLAN

LEGEND

- EXISTING BURIED ELECTRIC
- EXISTING OVERHEAD ELECTRIC
- EXISTING BURIED FIBER OPTIC
- PAVEMENT MARKING (BY OTHERS)

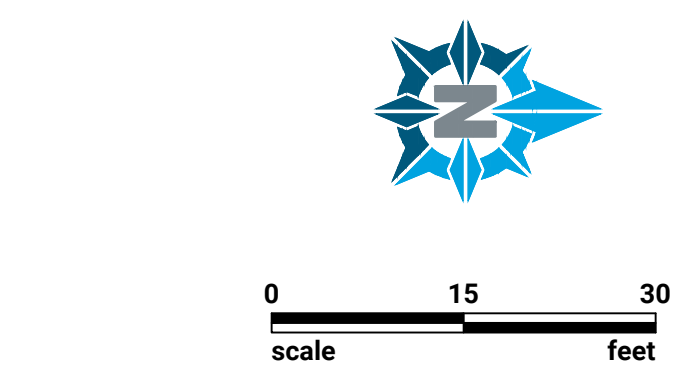

GENERAL NOTES:

- TOPOGRAPHIC BASE MAP PREPARED FROM 2026 FOTH SURVEY, 2025 TRANSFER STATION AND MRF PROJECT PROPOSED GRADES, SURVEY PERFORMED BY FOTH ON JULY 15, 2024, AND COLUMBIA COUNTY 2020 LIDAR.
- ASPHALT PAVEMENT AND PAVEMENT MARKINGS BY OTHERS. CONTRACTOR TO PLACE AND COMPACT BASE MATERIALS TO DESIGN SUBGRADES. COORDINATE AND FINISH GRADING AND PAVEMENT TIMING WITH SEPARATE CONTRACT.

ISSUED FOR BIDDING

DESIGNED: ATP	DRAWN: ATP	CHECKED: DJM4
PROJECT NO: 26C062.00		
PRINT DATE: 7/1/2026		
SHEET NO. C2.0		

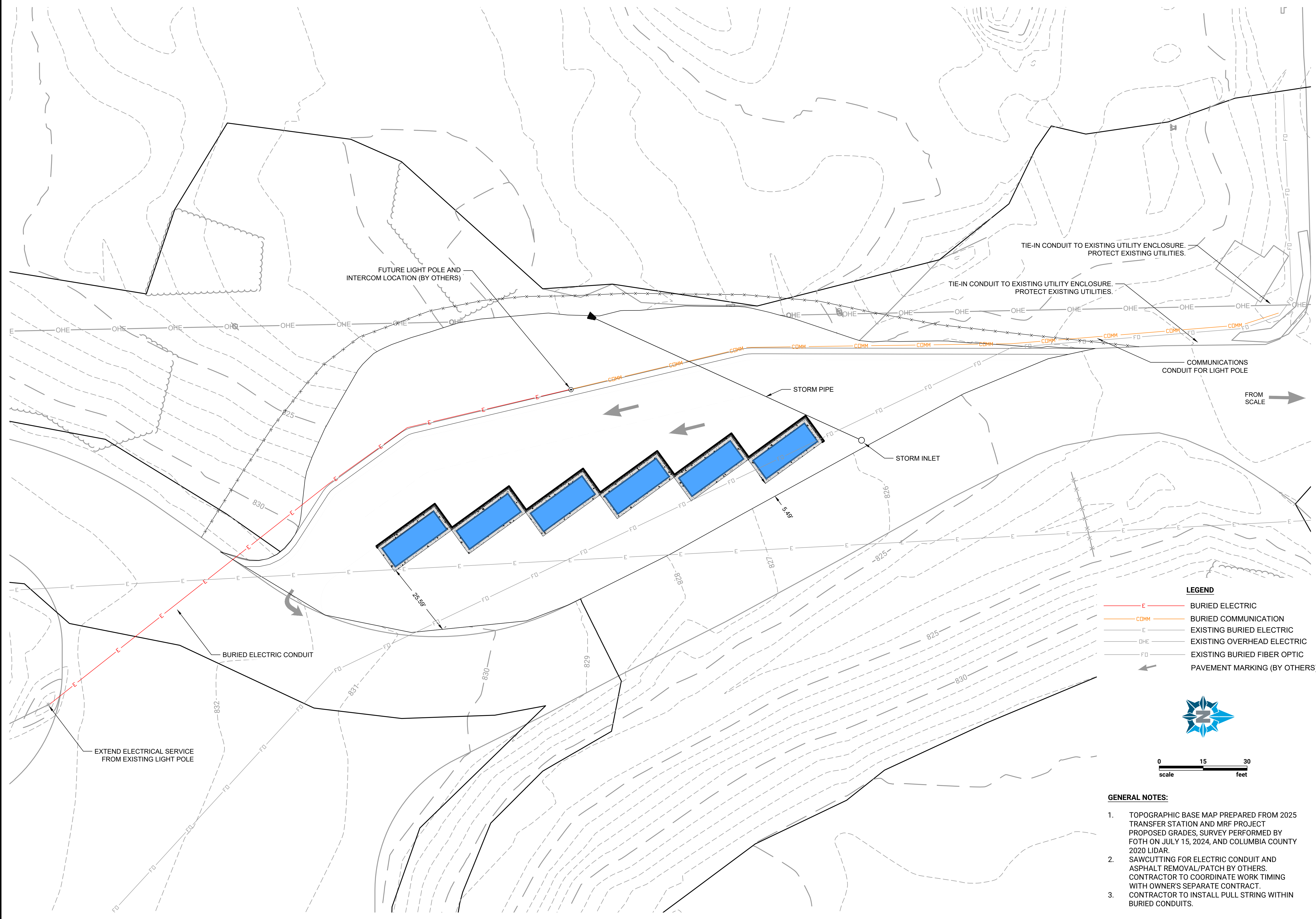

NO	DATE	BY	REVISION DESCRIPTION
1.	6/26/2026	ATP	ISSUED FOR OWNER REVIEW
2.	7/1/2026	ATP	ISSUED FOR BIDDING

RESIDENTIAL DROP-OFF
 COLUMBIA COUNTY RECYCLING & SOLID WASTE
 PARDEEVILLE, WISCONSIN

PROPOSED LIGHT POLE PLAN

LEGEND

	BURIED ELECTRIC
	BURIED COMMUNICATION
	EXISTING BURIED ELECTRIC
	EXISTING OVERHEAD ELECTRIC
	EXISTING BURIED FIBER OPTIC
	PAVEMENT MARKING (BY OTHERS)

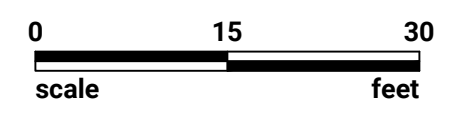

- GENERAL NOTES:**
- TOPOGRAPHIC BASE MAP PREPARED FROM 2025 TRANSFER STATION AND MRF PROJECT PROPOSED GRADES, SURVEY PERFORMED BY FOTH ON JULY 15, 2024, AND COLUMBIA COUNTY 2020 LIDAR.
 - SAWCUTTING FOR ELECTRIC CONDUIT AND ASPHALT REMOVAL/PATCH BY OTHERS. CONTRACTOR TO COORDINATE WORK TIMING WITH OWNER'S SEPARATE CONTRACT.
 - CONTRACTOR TO INSTALL PULL STRING WITHIN BURIED CONDUITS.

ISSUED FOR BIDDING

DESIGNED: ATP	DRAWN: ATP	CHECKED: DJM4
PROJECT NO: 26C062.00		
PRINT DATE: 7/1/2026		
SHEET NO.		
C2.1		

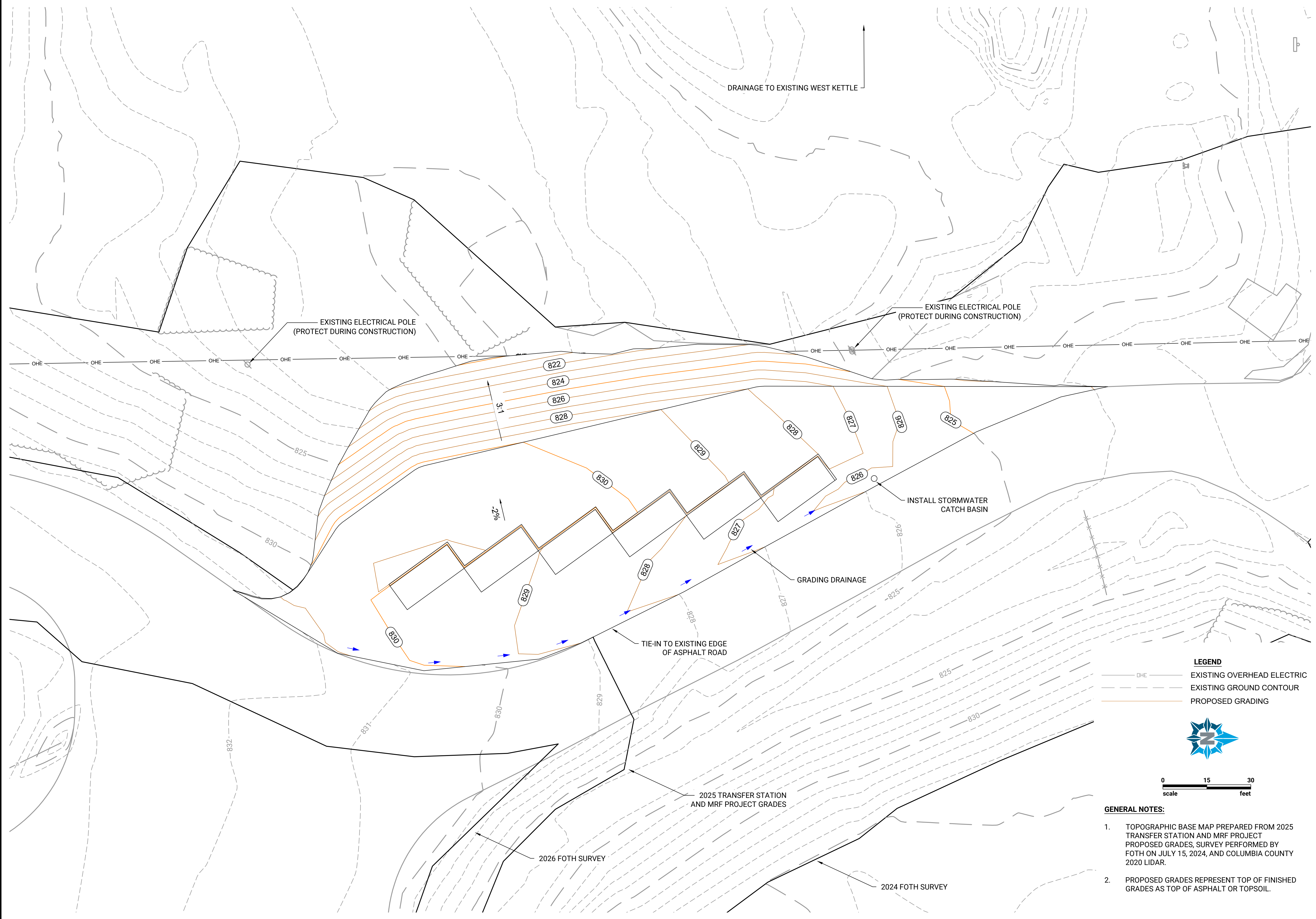

NO.	DATE	BY	REVISION DESCRIPTION
1.	6/26/2026	ATP	ISSUED FOR OWNER REVIEW
2.	7/1/2026	ATP	ISSUED FOR BIDDING

RESIDENTIAL DROP-OFF
 COLUMBIA COUNTY RECYCLING & SOLID WASTE
 PARDEEVILLE, WISCONSIN
PROPOSED GRADING PLAN

LEGEND
 EXISTING OVERHEAD ELECTRIC
 EXISTING GROUND CONTOUR
 PROPOSED GRADING

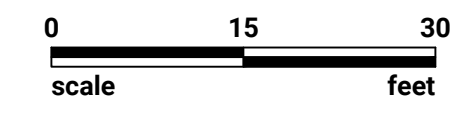

GENERAL NOTES:

- TOPOGRAPHIC BASE MAP PREPARED FROM 2025 TRANSFER STATION AND MRF PROJECT PROPOSED GRADES, SURVEY PERFORMED BY FOTH ON JULY 15, 2024, AND COLUMBIA COUNTY 2020 LIDAR.
- PROPOSED GRADES REPRESENT TOP OF FINISHED GRADES AS TOP OF ASPHALT OR TOPSOIL.

ISSUED FOR BIDDING

DESIGNED: ATP	DRAWN: ATP	CHECKED: DJM4
PROJECT NO: 26C062.00		
PRINT DATE: 7/1/2026		
SHEET NO.		

C3.0

NO.	DATE	BY	REVISION DESCRIPTION
1.	6/26/2026	ATP	ISSUED FOR OWNER REVIEW
2.	7/1/2026	ATP	ISSUED FOR BIDDING

GENERAL NOTES

- TRENCH SHALL BE A MINIMUM OF 4" WIDE & 6" DEEP TO BURY AND ANCHOR THE GEOTEXTILE FABRIC. FOLD MATERIAL TO FIT TRENCH AND BACKFILL & COMPACT TRENCH WITH EXCAVATED SOIL.
- WOOD POSTS SHALL BE A MINIMUM SIZE OF 1 1/8" X 1 1/8" OF OAK OR HICKORY.
- CONSTRUCT SILT FENCE FROM A CONTINUOUS ROLL IF POSSIBLE BY CUTTING LENGTHS TO AVOID JOINTS. IF A JOINT IS NECESSARY USE ONE OF THE FOLLOWING TWO METHODS; A) OVERLAP THE END POSTS AND TWIST, OR ROTATE, AT LEAST 180 DEGREES, B) HOOK THE END OF EACH SILT FENCE LENGTH.

NOTE: ADDITIONAL POST DEPTH OR TIE BACKS MAY BE REQUIRED IN UNSTABLE SOILS



1 SILT FENCE DETAIL
 C5.0 NOT TO SCALE

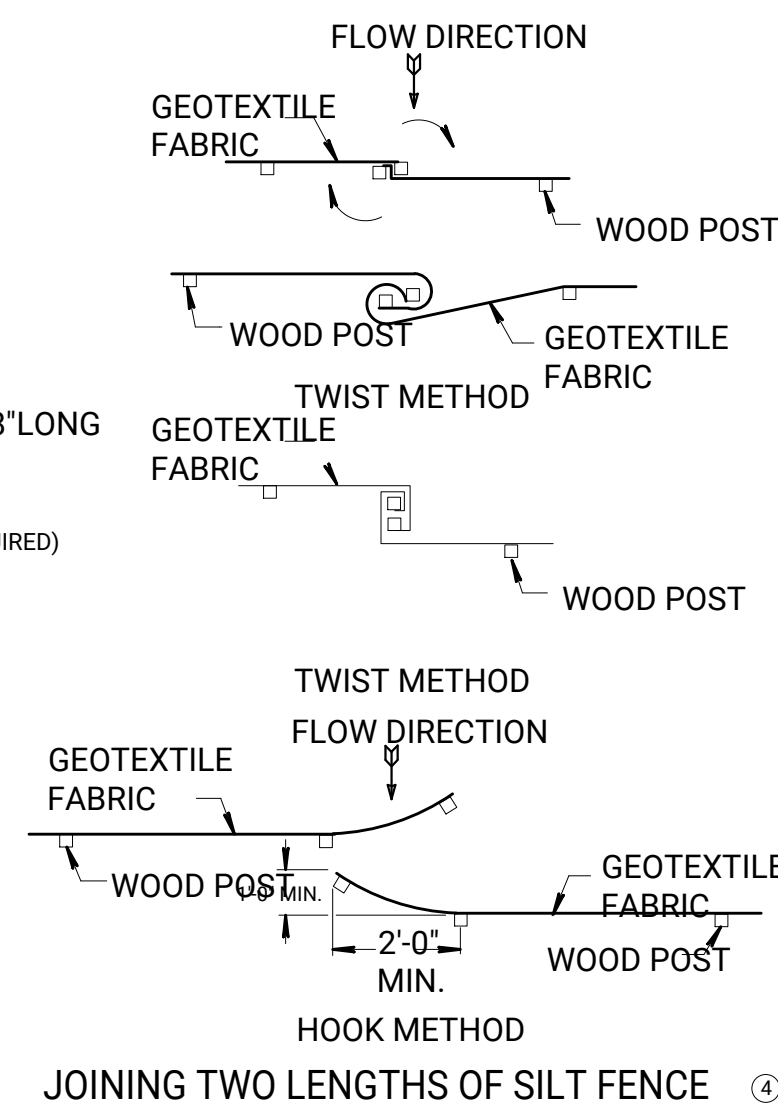
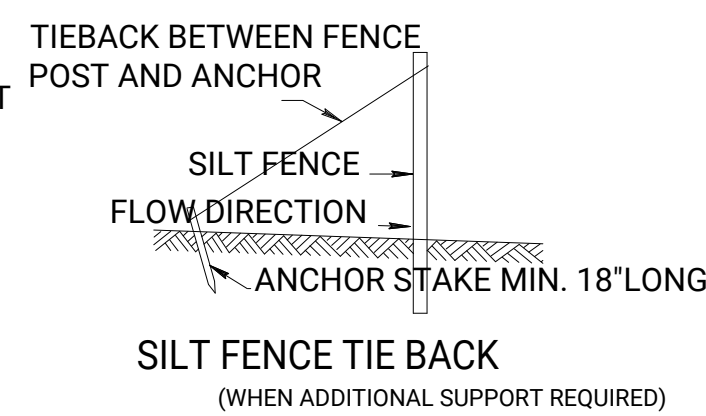

This drawing based on Wisconsin Department of Transportation Standard Detail Drawing 8 E 9-6.

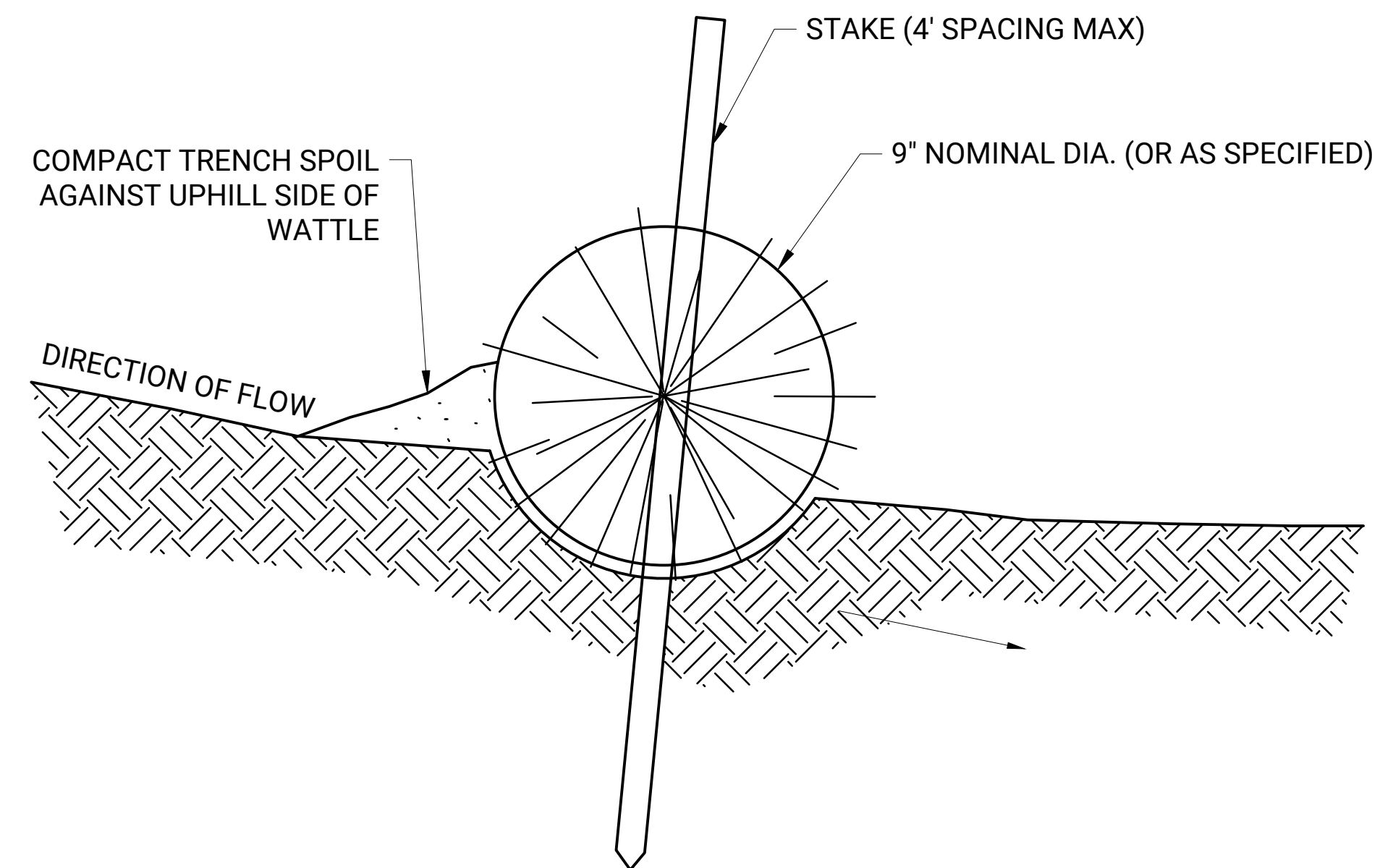

2 STRAW WATTLE SLOPE INTERRUPTION DETAIL
 C5.0 NOT TO SCALE

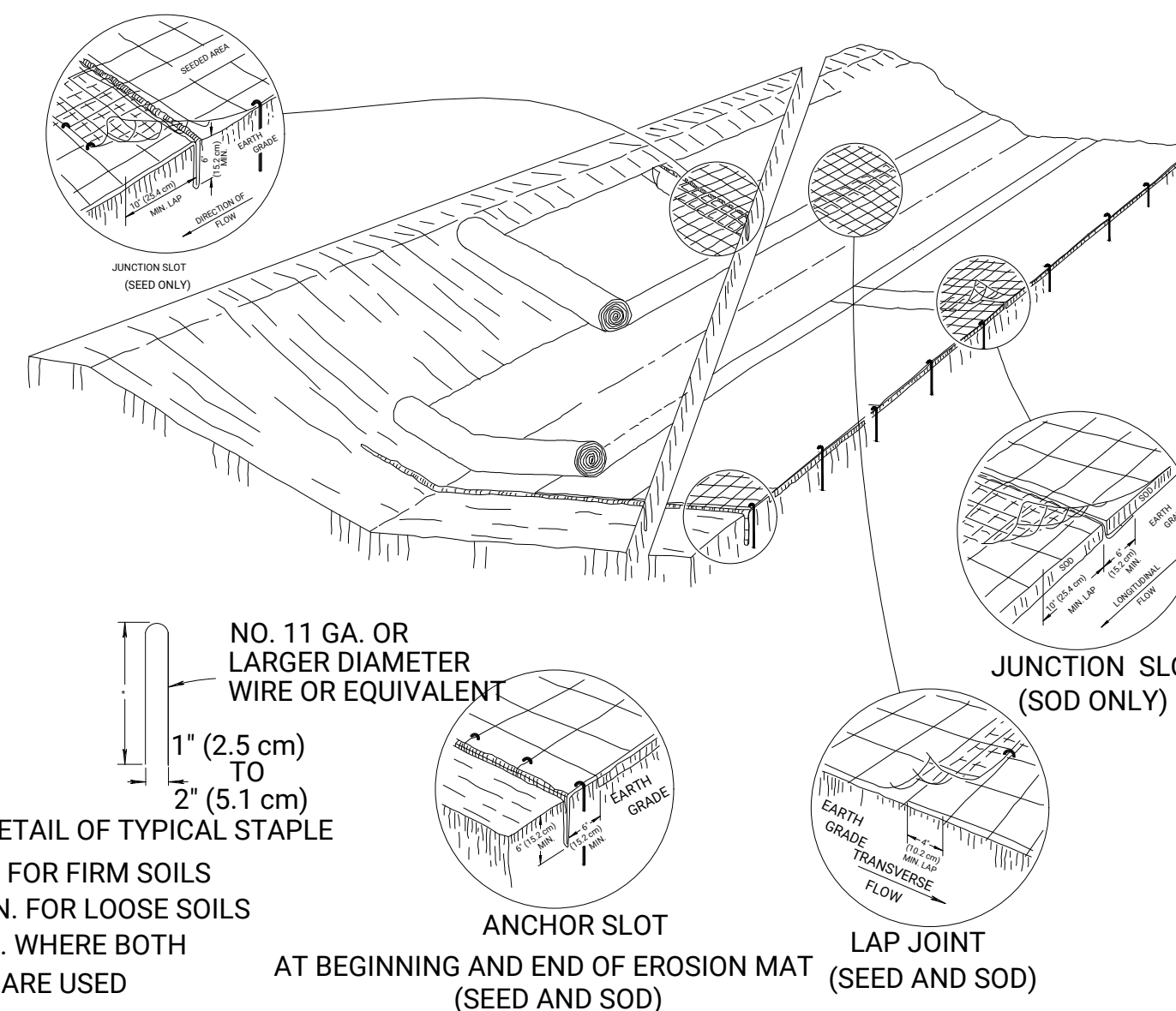

3 EROSION MAT DETAIL
 C5.0 NOT TO SCALE

GENERAL NOTES

- DETAILS OF CONSTRUCTION, MATERIALS AND WORKMANSHIP NOT SHOWN ON THIS DRAWING SHALL CONFORM TO THE PERTINENT REQUIREMENTS OF THE STANDARD SPECIFICATIONS AND THE APPLICABLE SPECIAL PROVISIONS. VARIATIONS IN THE DIMENSIONS OR MATERIALS SHOWN HEREON SHALL BE PERMITTED IF THEY PROVIDE EQUIVALENT PROTECTION AND MATERIAL STRENGTH AND IF PRIOR APPROVAL OF THE ENGINEER IS OBTAINED.
- LAP JOINTS SHALL NOT BE PLACED IN THE BOTTOM OF V-SHAPED DITCHES.
- JUNCTION SLOTS ON ADJACENT STRIPS OF MATTING SHALL BE STAGGERED A MINIMUM OF 4 FEET (1.219 m) APART.
- EDGES OF THE EROSION MAT SHALL BE IMPRESSED IN THE SOIL.
- EROSION MAT SHALL BE MEASURED AND PAID FOR IN ACCORDANCE WITH THE STANDARD SPECIFICATIONS.

EROSION MAT OVER SOD

- ONLY JUTE FABRIC WILL BE PERMITTED OVER SOD.
- WOOD STAKES FOR SOD MAY BE OMITTED BY THE ENGINEER IF THE EXISTING SLOPE AND SOIL CONDITIONS SO WARRANT. THE WIDTH OF THE EROSION MAT SHALL ALWAYS EQUAL THE SOD WIDTH.
- SOD STRIPS MAY BE PLACED EITHER LONGITUDINALLY OR TRANSVERSELY TO THE FLOW LINE OF THE DITCH.

EROSION MAT OVER SEEDING

- JUNCTION OR ANCHOR SLOTS SHALL BE AT MINIMUM INTERVALS OF 100 FEET (30.48 m) ON GRADES UP TO AND INCLUDING 3 PERCENT, AND 50 FEET (15.24 m) ON GRADES EXCEEDING 3 PERCENT.

RESIDENTIAL DROP-OFF
 COLUMBIA COUNTY RECYCLING & SOLID WASTE
 PARDEEVILLE, WISCONSIN

DETAILS

ISSUED FOR BIDDING

DESIGNED: ATP	DRAWN: ATP	CHECKED: DJM4
PROJECT NO: 26C062.00		
PRINT DATE: 7/1/2026		
SHEET NO. C5.0		

PAVEMENT SECTION NOTES:

1. ALL AGGREGATE BASE AND SELECT GRANULAR BORROW SHALL BE COMPACTED TO 100% STANDARD PROCTOR.

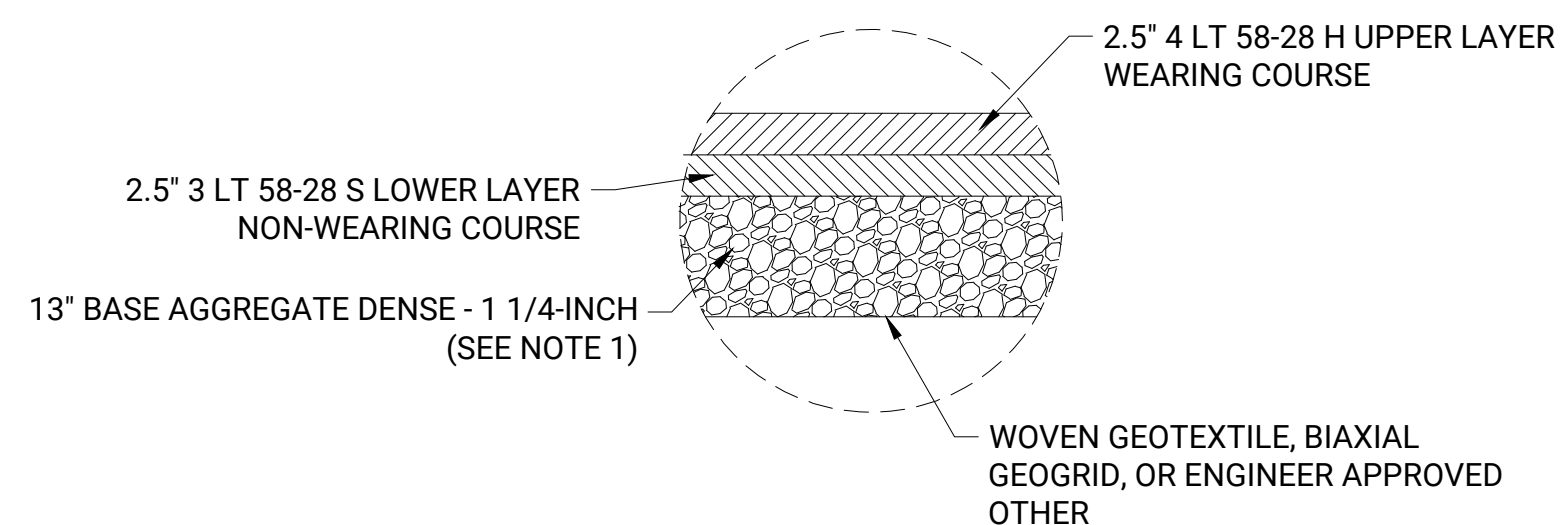

NOTE: PAVEMENT BY OTHERS UNDER SEPARATE CONTRACT. CONTRACTOR SHALL PREPARE SUB-BASE, INSTALL GEOSYNTHETICS, AND PLACE BASE MATERIALS.

1 HEAVY DUTY ASPHALT PAVEMENT SECTION
C5.1 NOT TO SCALE

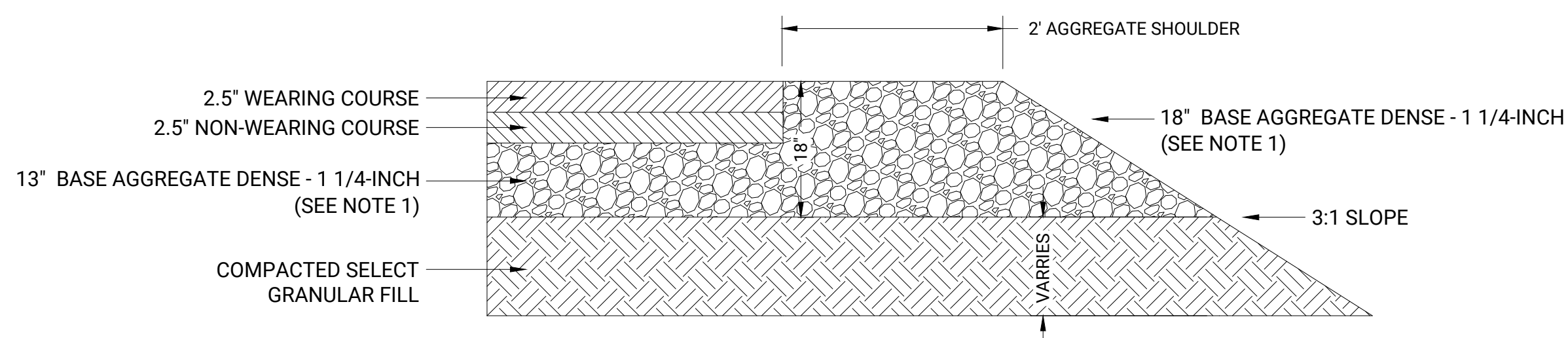

2 AGGREGATE TRANSITION DETAIL
C5.1 NOT TO SCALE

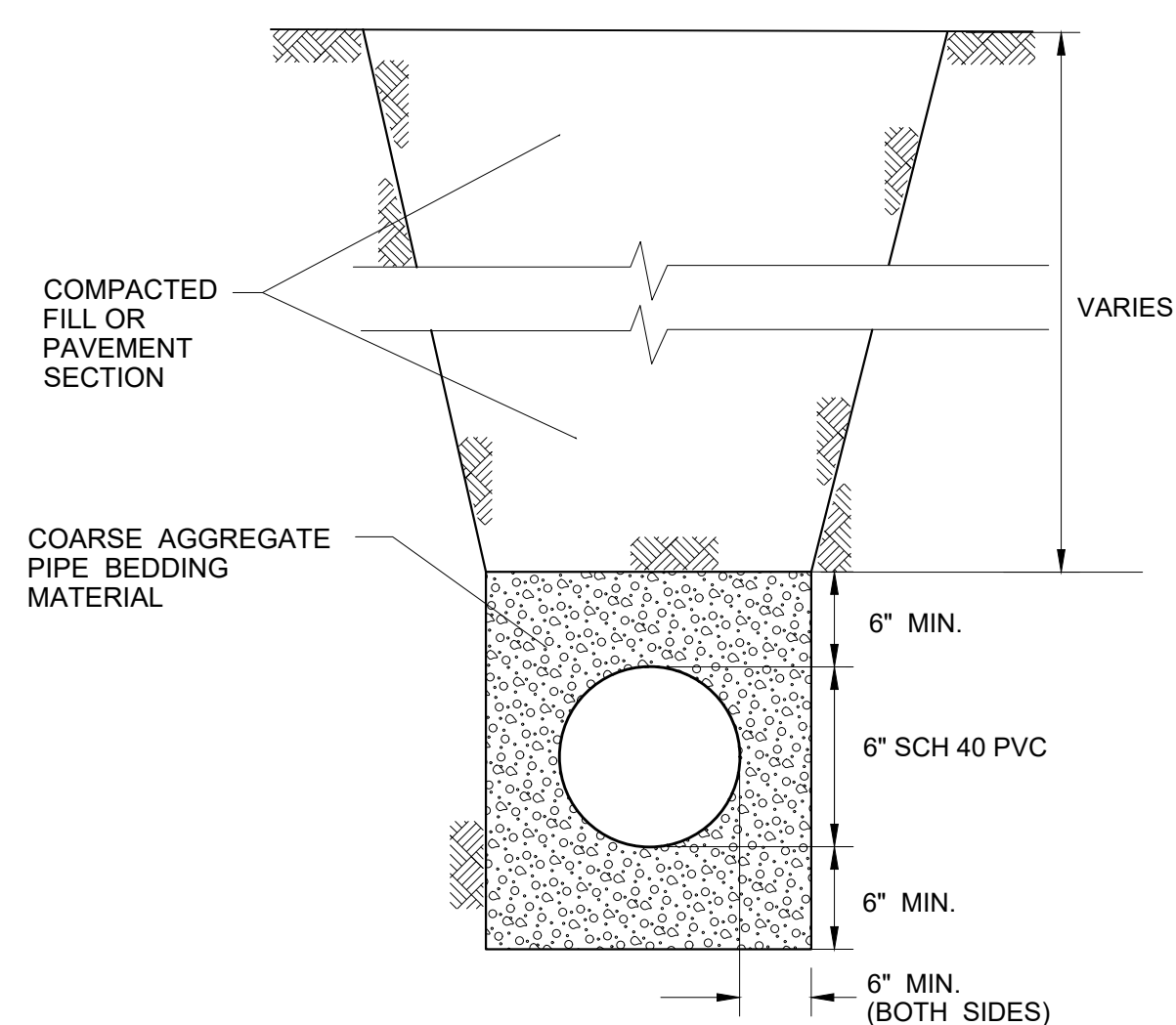

3 PIPE TRENCH DETAIL
C5.1 NOT TO SCALE

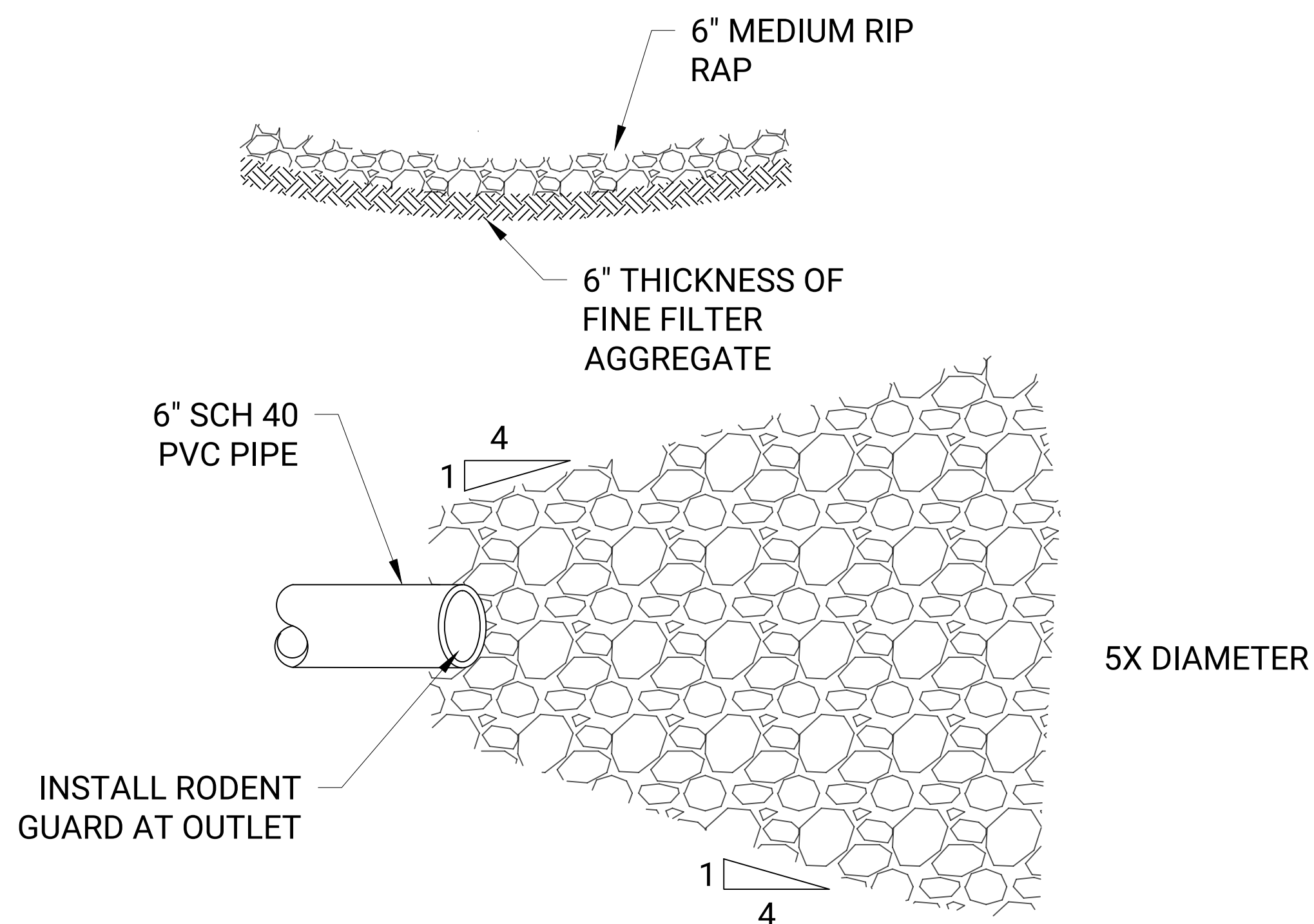

4 PIPE OUTLET PROTECTION
C5.1 NOT TO SCALE

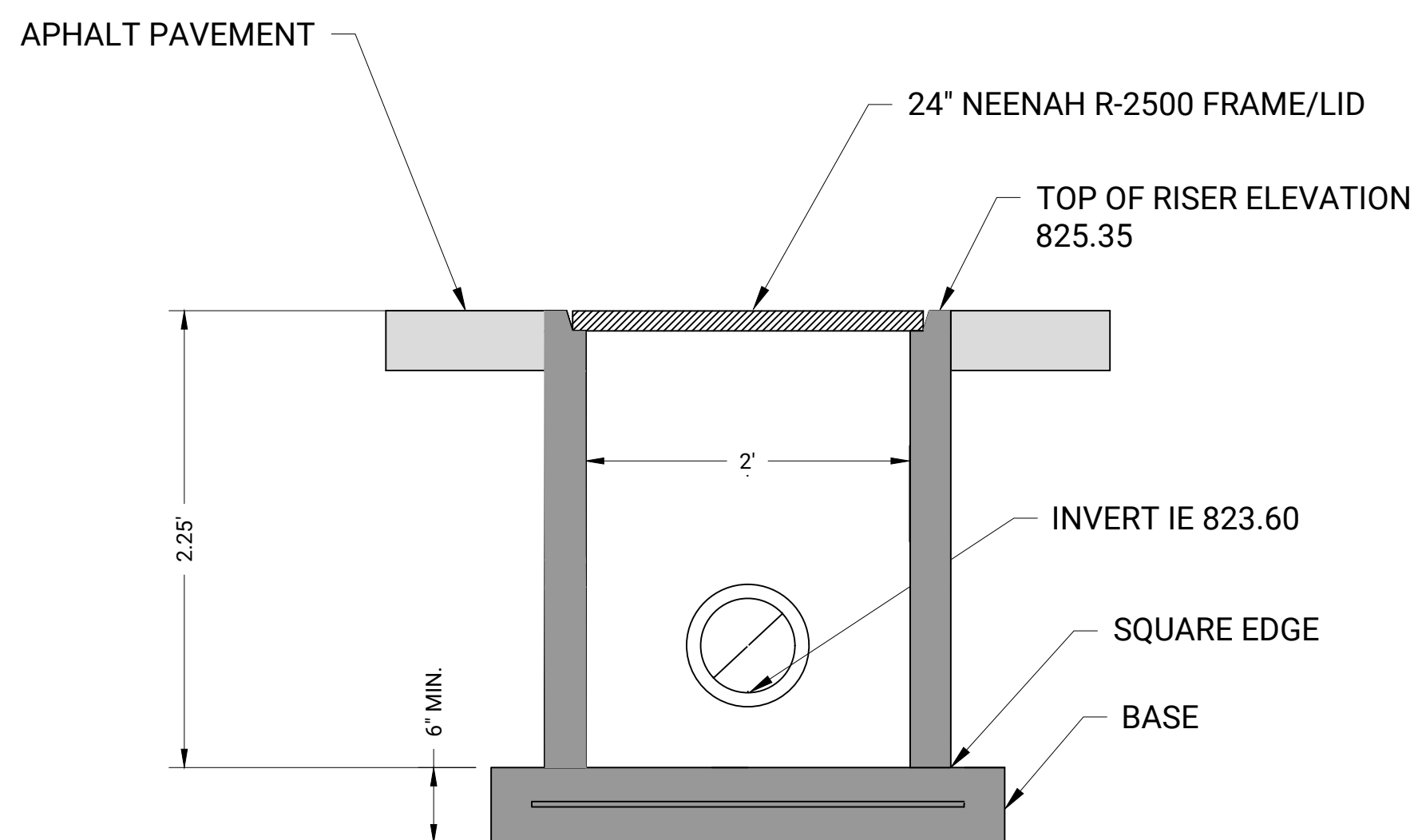

5 CATCH BASIN DETAIL
C5.1 NOT TO SCALE

NOTE: PRECAST REINFORCED CONCRETE MANHOLE CATCH BASIN, CONFORMING TO ASTM C-478. BASE CAST MONOLITHICALLY WITH BARREL SECTION. 3-INCH (MIN.) THICK CONCRETE WITH #6 WELDED, WIRE MESH ON 4 INCH CENTERS (WWF 4" X 4"). CENTER MESH VERTICALLY WITHIN BASE.

NO	DATE	BY	REVISION DESCRIPTION
1.	6/26/2026	ATP	ISSUED FOR OWNER REVIEW
2.	7/1/2026	ATP	ISSUED FOR BIDDING

RESIDENTIAL DROP-OFF
COLUMBIA COUNTY RECYCLING & SOLID WASTE
PARDEEVILLE, WISCONSIN

DETAILS

ISSUED FOR BIDDING

PREPARED FOR:



PREPARED BY:



NO.	DATE	BY	REVISION DESCRIPTION
1.	6/26/2026	ATP	ISSUED FOR OWNER REVIEW
2.	7/1/2026	ATP	ISSUED FOR BIDDING

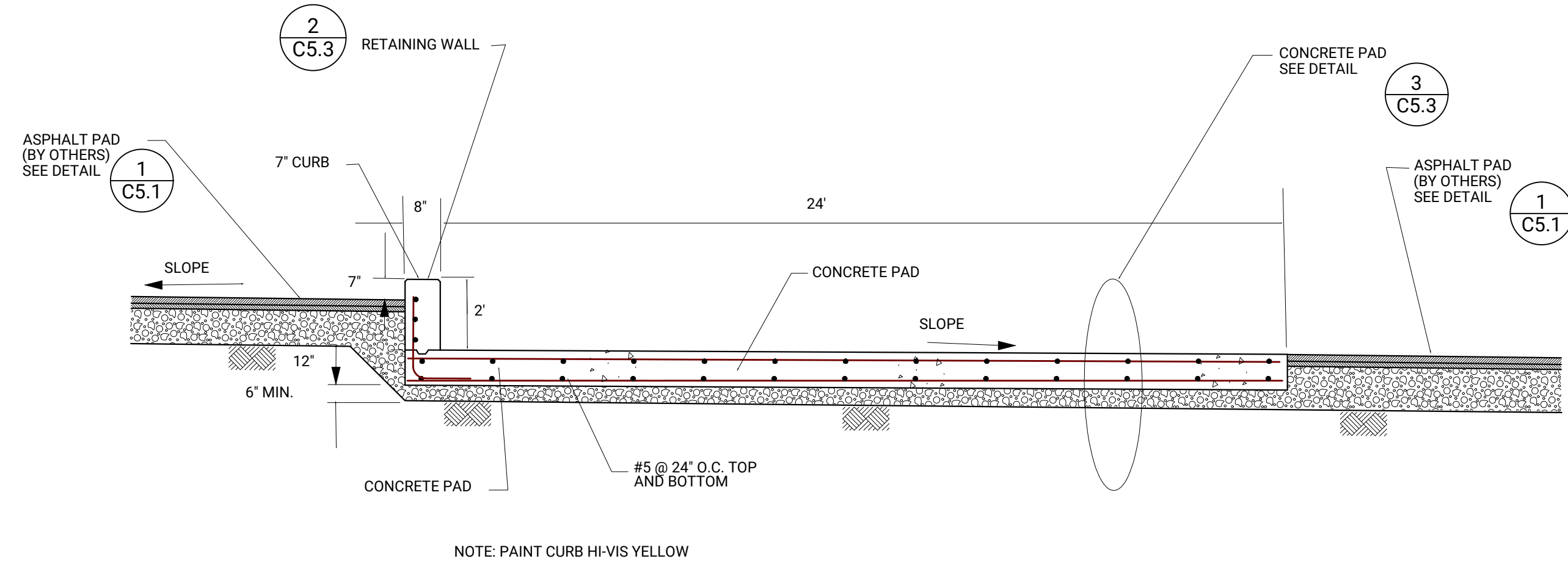

1 TYPICAL SECTION
C5.3 NOT TO SCALE

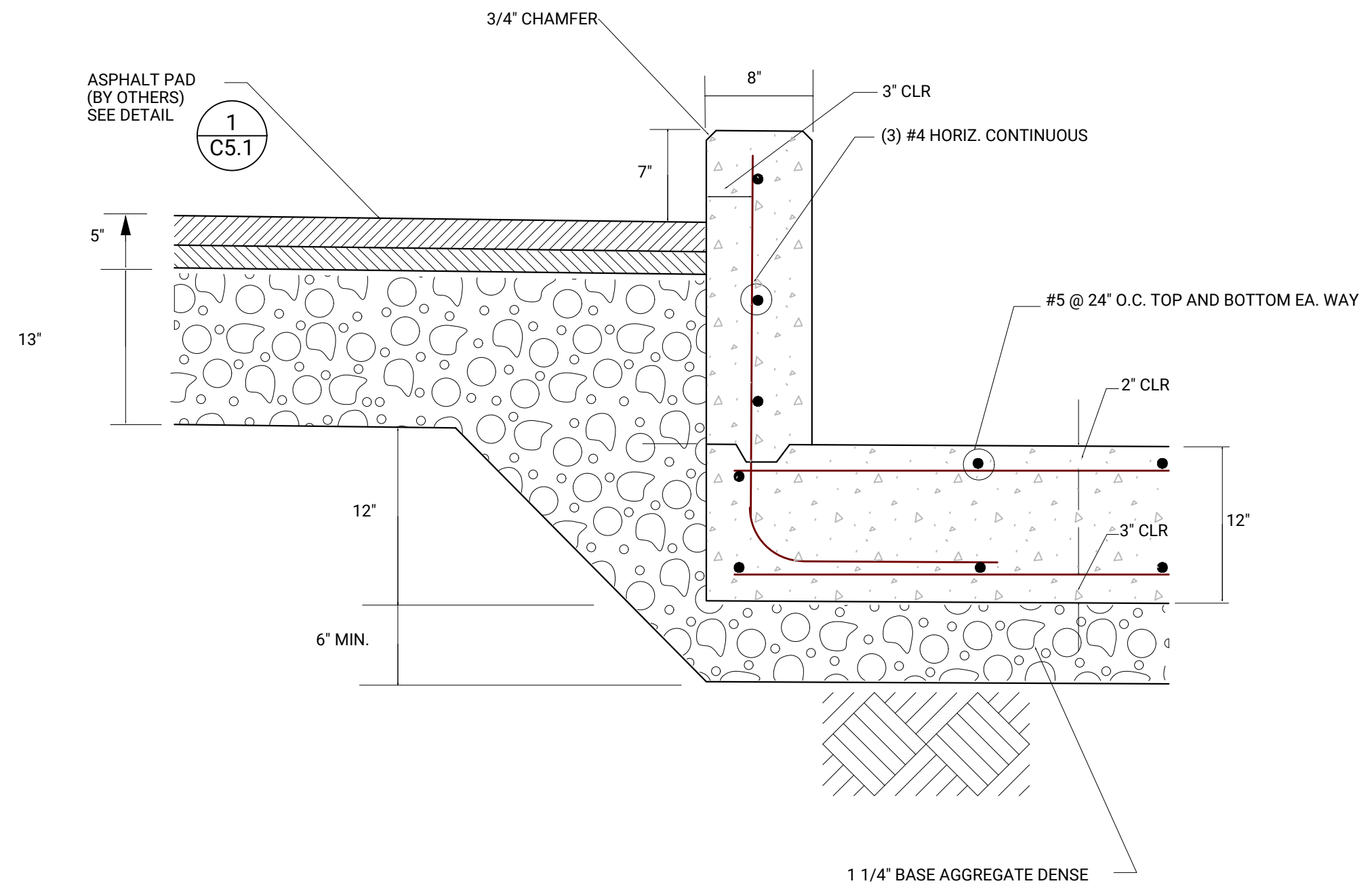

2 TYPICAL RETAINING WALL/CURB SECTION
C5.3 NOT TO SCALE

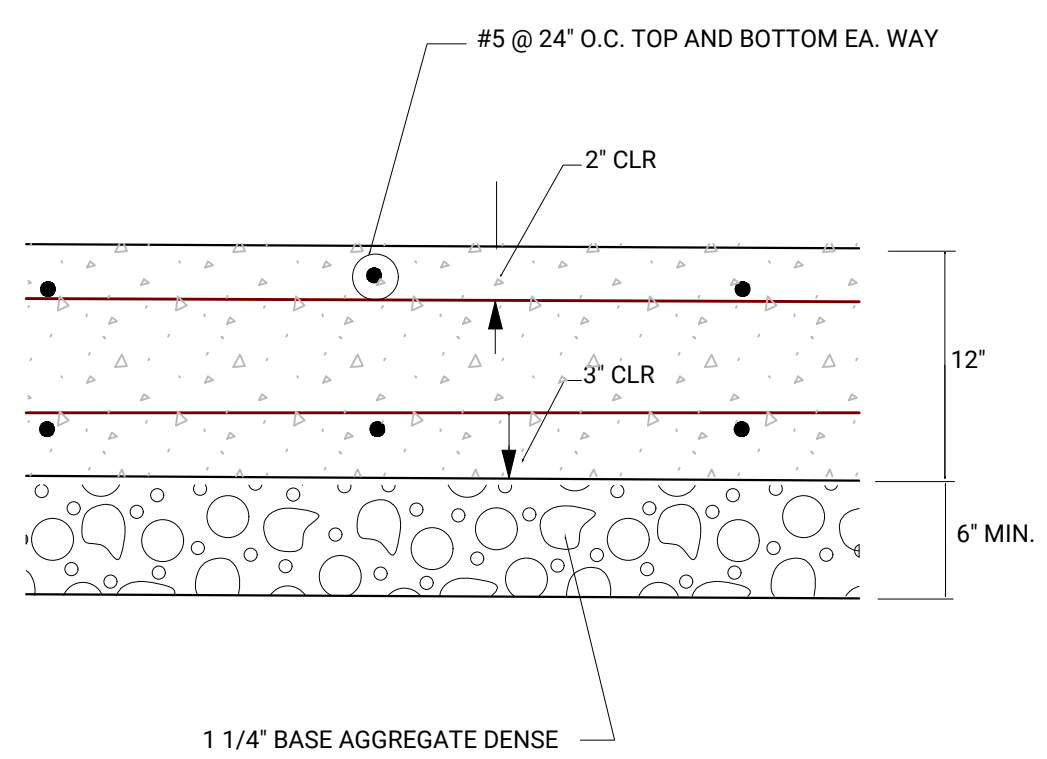

3 TYPICAL CONCRETE PAD DETAIL
C5.3 NOT TO SCALE

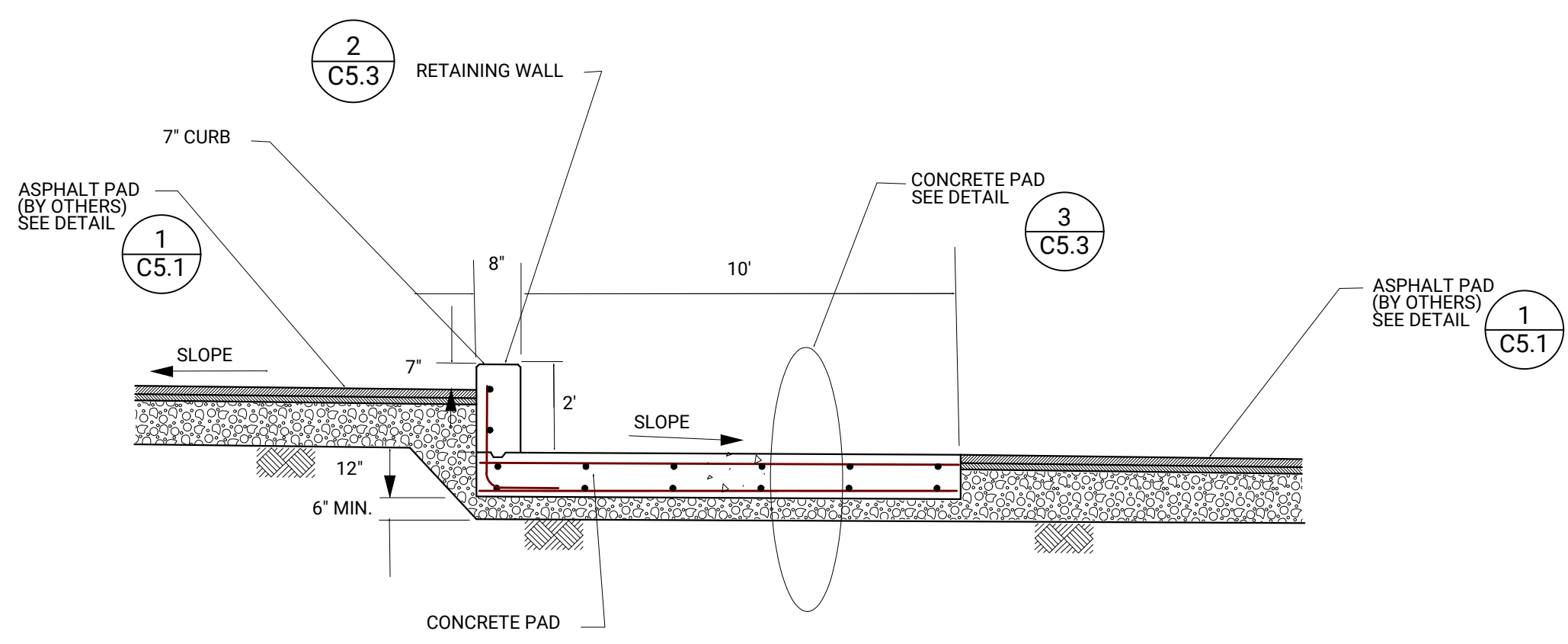

4 TYPICAL SECTION
C5.3 NOT TO SCALE

RESIDENTIAL DROP-OFF
COLUMBIA COUNTY RECYCLING & SOLID WASTE
PARDEEVILLE, WISCONSIN

DETAILS

ISSUED FOR BIDDING

DESIGNED: ATP	DRAWN: ATP	CHECKED: DJM4
PROJECT NO: 26C062.00		
PRINT DATE: 7/1/2026		
SHEET NO. C5.3		

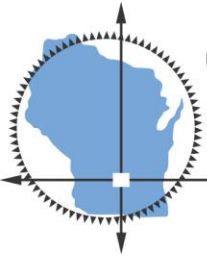

(Request For Bids/Proposals/Contracts)
Columbia County Purchasing Division

1.0 APPLICABILITY: These standard terms and conditions apply to Requests for Written Quotes (RFWQ), Proposals (RFP), contracts and all other applicable transactions whereby the County acquires goods or services, or both. Special provisions for a contract may also apply.

2.0 SPECIFICATIONS: The listed specifications are the minimum acceptable. When specific manufacturer and model numbers are used, they are to establish a design, type of construction, quality, functional capability or performance level, or any combination thereof, desired. When alternates are proposed, they must be identified by manufacturer, stock number, and such other information necessary to establish equivalency. The County shall be the sole judge of equivalency. Vendors are cautioned to avoid proposing alternates to the specifications that may result in rejection of their bid.

3.0 DEVIATIONS AND EXCEPTIONS: Deviations and exceptions from terms, conditions, or specifications shall be described fully on the vendor's letterhead, signed, and attached to the bid. In the absence of such statement, the bid shall be accepted as in strict compliance with all terms, conditions, and specifications and vendor shall be held liable for injury resulting from any deviation.

4.0 QUALITY: Unless otherwise indicated in the request, all material shall be first quality. No pre-owned, obsolete, discontinued or defective materials may be used.

5.0 QUANTITIES: The listed quantities shown herein are based on estimated needs. The County reserves the right to increase or decrease quantities to meet actual needs.

6.0 DELIVERY: Deliveries shall be FOB destination freight prepaid and included unless otherwise specified. County will reject shipments sent C.O.D. or freight collect.

7.0 PRICING: Unit prices shown on the bid shall be the price per unit of sale as stated on the request or contract. For any given item, the quantity multiplied by the unit price shall establish the extended price, the unit price shall govern in the bid evaluation, permits, inspections, and all other contract administration activities.

7.1 Prices established in continuing agreements and term contracts may be lowered due to market conditions, but prices shall not be subject to increase for the term specified in the award. Vendor shall submit proposed increases to the contracting department thirty (30) calendar days before the proposed effective date of the price increase. Proposed increases shall be limited to fully documented cost increases to the vendor that are demonstrated to be industry wide. Price increases may not be granted unless they are expressed in bid documents and contracts or agreements.

7.2 Submission of a bid constitutes bidder's certification that no financial or personal relationship exists between the bidder and any County official or employee except as specially set forth in writing attached to and made part of the bid. The successful bidder shall disclose any such relationship which develops during the term of the contract. See Columbia County Code of Ordinances Title 3, Chapter 1, Code of Ethics.

8.0 ACCEPTANCE-REJECTION: The County reserves the right to accept or reject any or all bids, to waive any technicality in any bid submitted and to accept any part of a bid as deemed to be in the best interests of the County. Submission of a proposal or a bid constitutes the making of an offer to contract and gives the County an option valid for 90 days after the date of submission to the County. The County reserves the right to perform background and reference checks on vendors providing goods and/or services to the County.

8.1 Bids **MUST** be dated and time stamped by the County on or before the date and time that the bid is due. Bids deposited or time stamped after the deadline will be rejected. Actual receipt by the County is necessary. Timely deposit in the mail is not sufficient. All bids must be clearly labeled with bidder name, return address, and bid title. THERE WILL BE NO EXCEPTIONS TO THIS POLICY.

9.0 METHOD OF AWARD: Award shall be made to the lowest responsible responsive vendor conforming to the specifications, terms, and conditions, or to the most advantageous bid submitted to the County on a quality versus price basis.

10.0 ORDERING/ACCEPTANCE: Written notice of award to a vendor in the form of a purchase order or other document, mailed or delivered to the address shown on the bid will be considered sufficient notice of acceptance of bid. A formal contract signed by both parties shall be used.

10.1 SUBCONTRACTING: Awarded vendor(s) will not be permitted to sublet, sell, transfer, assign or otherwise dispose of the contract or any portion therein, or its right, title, or interest in the contract to any person, vendor(s) or other organization without the prior written consent of the County. No subcontract shall, under any circumstances, relieve the contractor of liability and obligation under this contract. The awarded contractor shall be fully responsible for the acts, errors, and omission of subcontractor(s).

11.0 PAYMENT TERMS AND INVOICING: Unless otherwise agreed, the County will pay properly submitted vendor invoices within forty five (45) days of receipt of goods and services. Payment will not be made until goods or services are delivered, installed (if required), and accepted as specified. Invoices presented for payment must be submitted in accordance the contract.

11.1 NO WAIVER OF DEFAULT: In no event shall the making of any payment or acceptance of any service or product constitute or be construed as a waiver by the County of any breach of the covenants of a contract, or a waiver of any default of the successful vendor. The making of any such payment or acceptance of any such service or

product by the County while any such default or breach shall exist shall in no way impair or prejudice the right of the County with respect to recovery of damages or other remedy as a result of such breach or default.

12.0 TAXES: The County and its departments are exempt from payment of all federal tax and Wisconsin state and local taxes on its purchases except Wisconsin excise taxes as described below. The Federal Government Internal Revenue Service has issued tax exempt number 39-6005681 to the County.

12.1 The County is required to pay the Wisconsin excise or occupation tax on its purchase of motor vehicle fuel. The County is exempt from Wisconsin sales or use tax on these purchases. The County may be subject to other states' taxes on its purchases in that state depending on the laws of that state. Vendors performing construction activities are required to pay state use tax on the cost of materials.

13.0 GUARANTEED DELIVERY: Failure of the vendor to adhere to delivery schedules as specified or to promptly replace rejected materials shall render the vendor liable for all costs in excess of the contract price when alternate procurement is necessary. Excess costs shall include administrative costs.

14.0 APPLICABLE LAW AND VENUE: This contract shall be governed under the laws of the State of Wisconsin, and venue for any legal action between the parties shall be in the Columbia County Circuit Court. The vendor shall at all times comply with and observe all federal and state laws, local laws, ordinances, and regulations which are in effect during the period of a contract and which in any manner affect the work or its conduct. The County also has the right to cancel a contract with any federally or state debarred contractor or a contractor that is presently identified on the list of parties excluded from federal procurement and non-procurement contracts.

15.0 ASSIGNMENT: No right or duty in whole or in part of the vendor under a contract may be assigned or delegated without the prior written consent of the County.

16.0 NONDISCRIMINATION/AFFIRMATIVE

ACTION: The vendor agrees, in accordance with Sec. 111.321, Wis. Stats. not to discriminate against any person, whether an applicant or recipient of services, an employee, or applicant for employment, on the basis of age, race, ethnicity, religion, color, gender, disability, marital status, sexual orientation, national origin, cultural differences, ancestry, physical appearance, arrest record or conviction record, military participation or membership in the national guard, state defense force or any other reserve component of the military forces of the United States, or political beliefs. The vendor shall provide a harassment-free work environment. These provisions shall include, but not be limited to, the following: employment, upgrading, demotion, transfer, recruitment, advertising, layoff, termination, training, including apprenticeships, rates of pay or other forms of compensation. Failure to comply with these Terms and Conditions may result in the vendor being debarred, termination of the contract and/or withholding of payment.

17.0 PATENT, COPYRIGHT AND TRADEMARK

INFRINGEMENT: The vendor guarantees goods sold to the County were manufactured or produced in accordance with applicable federal labor laws, and that the sale or use of the articles described herein do not infringe any patent, copyright or trademark. The vendor covenants that it will, at its own expense, defend every suit which shall be brought against the County (provided that such vendor is promptly notified of such suit, and all papers therein are delivered to it) for any alleged infringement of any patent, copyright or trademark by reason of the sale or use of such articles, and agrees that it will pay all costs, damages, and profits recoverable in any such suit.

18.0 SAFETY REQUIREMENTS:

All materials, equipment, and supplies provided to the County must fully comply with all safety requirements as set forth by the Wisconsin Department of Safety and Professional Services and all applicable OSHA Standards. The vendor shall also comply with the County's worksite rules. Vendor shall comply, train, and accept exclusive responsibility for its employees while on County property.

18.1 MATERIAL SAFETY DATA SHEET: If any item(s) on an order(s) resulting from an award(s) is a hazardous chemical, as defined under 29 CFR 1910.1200, the vendor must provide one (1) copy of the Material Safety Data Sheet for each item with the shipped container(s) and one (1) copy with the invoice(s).

19.0 WARRANTY: Unless specifically expressed otherwise in writing, goods and equipment purchased by the County shall be warranted against defects by the vendor for one (1) year from the date of receipt. An equipment manufacturer's standard warranty shall apply as a minimum and must be honored by the vendor.

20.0 INDEMNIFICATION & INSURANCE: The vendor shall bear the full and complete responsibility for all risk of damage of premises, equipment, procedure or money resulting from any cause whatsoever and shall not penalize the County for any losses incurred.

Vendor shall indemnify the County against any loss, damage, injury or death caused by vendor's negligent acts or omissions or the negligent acts or omissions of vendor's agents or employees, or losses, damages, injuries or death caused by vendor's negligence and arising out of the consumption or use of the projects sold; provided, however, that nothing contained herein shall require vendor to defend or indemnify the County for losses, damages, injuries or death arising out of the negligence of the County, its agents or employees. In order to secure vendor's obligation to hold harmless and indemnify the County, vendor shall procure and maintain the following insurance:

1. Worker's Compensation Insurance as prescribed by the laws of the State of Wisconsin;
2. Comprehensive Automobile Bodily Injury Liability and Property Damage Liability Insurance, with limits of \$500,000 for bodily injury or death of any one person, \$1,000,000 for bodily injury or death of two or more persons in any one accident, and \$100,000 for property damage in any one accident;
3. Comprehensive General Bodily Injury Liability and Property Damage Liability

Insurance, with limits of \$500,000 for bodily injury or death of any one person, \$1,000,000 for bodily injury or death of two or more persons in any one accident, and \$100,000 for property damage in any one accident;

4. Commercial General Liability of \$2,000,000 for general aggregate including product and \$1,000,000 for each occurrence;

The vendor shall add the County, its officers, agents and employees and additional insurers under the Commercial, General and Automobile liability policies.

20.1 CERTIFICATE OF INSURANCE: Upon notification of award and prior to issuance of contract, the vendor shall provide the County a Certificate of Insurance with the required coverage and limits of insurance.

21.0 CANCELLATION: The County reserves the right to terminate any contract in whole or part without penalty due to non-appropriation of funds or failure of vendor/ contractor to comply with terms, conditions, performance, and specifications of a contract.

22.0 PUBLIC RECORDS ACCESS: It is the intention of the County to maintain an open and public process in the solicitation, submission, notice of bid opening, review, and approval of procurement activities. Bid openings are public unless otherwise specified.

22.1 PROPRIETARY INFORMATION: Any restrictions on the use of data contained within a request must be clearly stated in the bid/proposal itself. Proprietary information submitted in response to a request will become the property of the County. The County will work with vendors to meet their confidentiality requirements, provided they are within reason. All vendors' proprietary/confidential materials must have each document or item clearly marked as such. All proprietary information will be handled in accordance with the Wisconsin public records law. However, when accepted, it is the vendor's responsibility to defend the determination in the event of an appeal or litigation.

22.2 Any material submitted by a vendor that the vendor considers confidential and proprietary information and which the vendor believes qualifies as a trade secret, as provided in Section 19.36(5) Wis. Stats., must be identified by the vendor. Pricing will not be held confidential after the award of a contract.

22.3 Data contained in a bid, all documentation provided therein, and innovations developed as a result of contracted commodities or services cannot be copyrighted or patented. All data, documentation, and innovations shall be the property of the County.

23.0 PROMOTIONAL ADVERTISING: Reference to or use of the County, any of its departments or sub-units, or any county official or employee for commercial promotion is prohibited without prior specific authorization.

24.0 ANTITRUST ASSIGNMENT: The vendor and the County recognize that in actual economic practice, overcharges resulting from antitrust violation are in fact usually borne by the purchaser. Therefore, the successful vendor hereby assigns to the County any and all claims for overcharges as to goods, materials or services purchased in connection with a contract.

25.0 RECORDKEEPING AND RECORD RETENTION - PUBLIC WORKS CONTRACTS: The successful bidder on a public works contract shall comply with the State of Wisconsin prevailing wage scale, if applicable, and shall establish and maintain adequate payroll records for all labor utilized as well as records for expenditures relating to all sub-contracts and suppliers. All records must be kept in accordance with generally accepted accounting procedures. The County shall have the right to audit, review, examine, copy, and transcribe any such records or documents. The vendor will retain all documents applicable to a contract for a period of not less than five (5) years after final payment is made.

25.1 RECORDKEEPING AND RECORD RETENTION - COST REIMBURSEMENT CONTRACTS: Where payment to a vendor is based on the vendor's costs, vendor shall establish and maintain adequate records of all expenditures

incurred under the contract. All records must be kept in accordance with generally accepted accounting procedures. The County contracting agency shall have the right to audit, review, examine, copy, and transcribe any pertinent records or documents relating to any contract resulting from a bid/proposal held by the vendor. The vendor will retain all documents applicable to the contract for a period of not less than five (5) years after final payment is made.

failure to perform such must be beyond the reasonable control and without the fault or negligence of the party.

26.0 LICENSURE, CERTIFICATION, AND STATUTORY REQUIREMENTS: Vendor is responsible to comply with all statutory rules and regulations. All federal, state and local laws, rules and regulations governing the service described in the specification will apply and will be deemed incorporated into the contract. These requirements shall be at the vendors' expense.

26.1 Vendor shall be responsible for ensuring compliance with all Wisconsin and Federal grant funding requirements. If any of the services performed under a contract are subcontracted, the selected vendor shall ensure compliance by all subcontractors. Vendor shall comply with all reporting requirements of any grant.

26.2 The County, the Federal Government, auditors for the State of Wisconsin, or their duly authorized representatives, will have full access to and the right to examine any site, pertinent books, documents, paper and records of any invoicing transaction for a period of not less than five (5) years after the expiration or termination of a contract.

27.0 CONFIDENTIALITY OF PERSONAL HEALTH INFORMATION: HIPAA/HITECH laws apply.

28.00 FORCE MAJEURE: Neither party shall be in default by reason of any failure in performance of a contract in accordance with reasonable control and without fault or negligence on its part. Such causes may include, but are not restricted to, acts of nature or the public enemy, acts of the government in either its sovereign or contractual capacity, fires, floods, epidemics, quarantine restrictions, strikes, freight embargoes and unusually severe weather, but in every case the